

1310/1490 Integrated Diplexer Transceiver

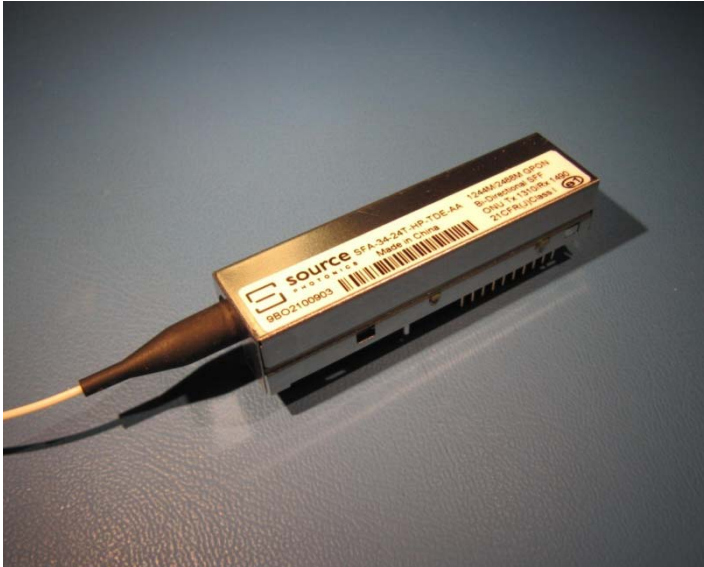

Features

- Single Fiber, Integrated Diplexer Transceiver
- 2x5 SFF pinout
- 2x10 SFF pinout supports I²C digital diagnostics
- Voice/Data FTTx ONT/ONU Applications
- Fully compliant to FSAN G.984.5 Specifications
- 1244 Mbps Tx, 2488 Mbps Rx Asymmetric Data Rate
- 1310 nm Tx, 1490 nm Rx
- Burst Mode Transmission
- Commercial & Industrial temperature versions available
- 28 dB link budget; 20 km reach
- Compliant to IEC-60825 Class 1 laser diode
- SC/APC or SC/UPC fiber connector
- RoHS-6/6 compliant

- **Digital Transmitter:** A DFB laser diode is employed for upstream transmission at OC-24 (1244Mbps). The optical transmitter includes a back facet photodetector to monitor laser power for APC control.

- **Digital Receiver:** An APD with TIA is employed for downstream data reception at OC-48 (2488Mbps). A post amplifier is also included for CML output compatibility.

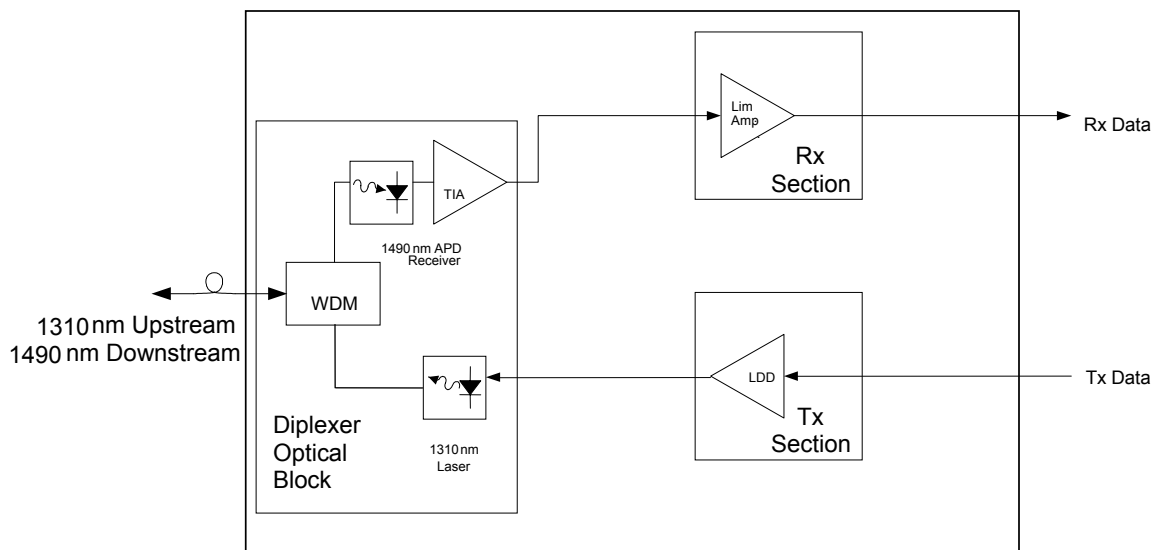

Diplexer Block Diagram

Absolute Maximum Ratings

Usage of this transceiver shall adhere to the following absolute maximum ratings. Stresses beyond those in Table 1 may cause permanent damage to the unit. These are stress ratings only, and functional operation of the unit at these or any other conditions beyond those indicated in the operational sections of the specifications is not implied. Exposure to absolute maximum rating conditions for extended periods may affect unit reliability.

Table 1 - Absolute Maximum Ratings

Parameter	Minimum	Maximum	Unit/Conditions
Ambient Storage Temperature	-40	85	°C
Operating Temperature*	-40	85	°C, I-Temp
	0	70	°C, C-Temp
Operating Humidity Range	10%	90%	non-condensing
ESD Sensitivity (Human Body Model)	-	1000	V
Lead Soldering Temperature	-	260°C	10 sec
Vcc_Rx	-0.4	+4.2	V
Vcc_Tx	-0.4	Vcc_Rx + 1	V

*Operating temperature Minimum is ambient; Maximum is module case temperature

Module Characteristics

Table 2 - Module Characteristics

Parameter	Minimum	Typical	Maximum	Unit/Conditions
1310nm Tx to 1490nm Rx Crosstalk	-	-	-47	dB
1555nm Rx to 1490nm Isolation	30	-	-	dB
G.984.5 Wavelength Blocking Filter (WBF)	7	-	-	dB, 1441 nm to 1450 nm
	7	-	-	dB, 1530 nm to 1539 nm
	22	-	-	dB, 1400 nm to 1441 nm
	22	-	-	dB, 1539 nm to 1625 nm
Total TX and RX Supply Current	-	-	350	mA

Functional Characteristics

The following tables list the performance specifications for the various functional blocks of the integrated optical transceiver module.

Table 3 – Digital Transmitter Specifications

Parameter	Minimum	Typical	Maximum	Unit	Notes
Operating Voltage	3.14	3.30	3.46	V	V _{CC} referenced to GND_Tx
Data Rate	-	1244.16	-	Mbps	
Average Optical Output Power, P _O	0.5	-	5	dBm	
Output Power at Transmit Off	-	-	-40	dBm	
Extinction Ratio	10	-	-	dB	PRBS 2 ²³ -1, NRZ, 50% duty cycle
Transmitter Output Eye	G.984.2 Figure 3				
Optical Rise and Fall Time	-	250	-	ps	20% to 80%
Center Wavelength	1290		1330	nm	
Differential Input Voltage, V _{in}	200	-	1600	mVp-p	BEN+/- and TXD+/- DC-coupled
Input Impedance, differential	-	100	-	Ω	BEN+/-, TXD+/-
Common-Mode Input Voltage	GND_Tx + 1.4	-	V _{CC} - (V _{in} /2) - 0.1	V	DC coupled
Tx Burst Enable Time	-	-	12.86	ns	16 bits data @ 1244Mbps
Tx Burst Disable Time	-	-	12.86	ns	16 bits data @ 1244Mbps
Jitter Generation	-	-	0.2	UI	4 kHz to 10 MHz

Refer to Figure 1 which schematically describes the high speed data inputs/outputs of the optical transceiver module.

For CML
Tx/Rx Data

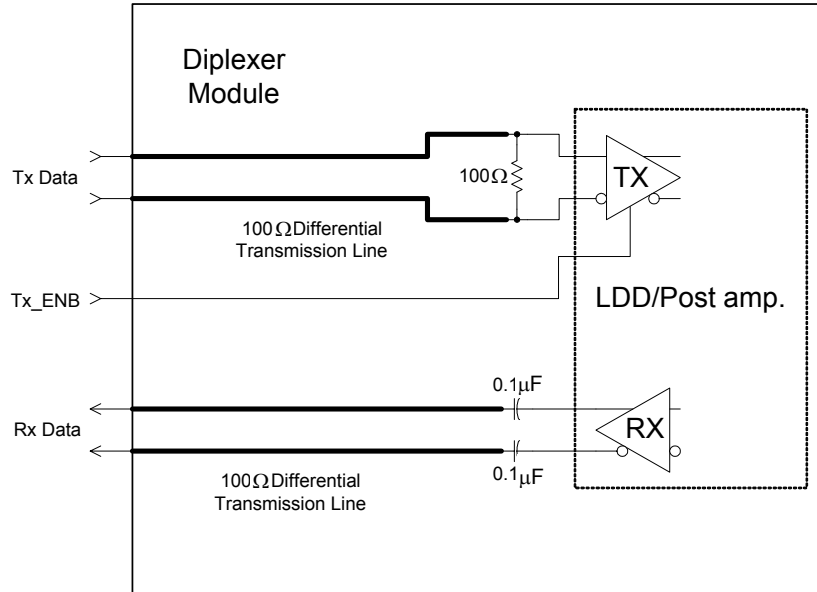

Figure 1 - Schematic representation of the module high speed inputs/outputs

Table 4 – Digital Receiver Specifications

Parameter	Minimum	Typical	Maximum	Unit	Notes
Operating Voltage	3.14	3.30	3.46	V	V _{CC} referenced to GND_RX
Data Rate	-	2488.32	-	Mbps	
Operational Wavelength Range	1480	-	1500	nm	
Received Optical Power	-28.0	-	-8	dBm	PRBS 2 ²³ -1, 50% duty cycle
Data Output Rise and Fall Time	-	160	-	ps	20% to 80%
Signal Detect Assertion Level	-	-	-28	dBm	Transition during increasing light
Signal Detect De-Assertion Level	-40	-	-	dBm	Transition during decreasing light
Signal Detect Hysteresis	0.5	-	-	dB	
Differential Output Voltage	300	-	1200	mV	CML output, ac coupled (0.1μF)
Signal Detect Output HIGH Voltage	2.4	-	-	V	LVTTTL with internal 4.7kΩ pull up resistor. Asserts HIGH when input data amplitude is above threshold.
Signal Detect Output LOW Voltage	-	-	0.6	V	LVTTTL. De-asserts LOW when input data amplitude is below threshold .
RSSI Range	-28	-	-8	dBm	2x10 only
RSSI Accuracy	-3	-	+3	dB	2x10 only

Table 5 - Microcontroller Specifications

Parameter	Minimum	Typical	Maximum	Unit	Notes
Operating Voltage	3.14	3.30	3.46	V	
SDA ^a	-	-	-	-	LVTTTL, open collector serial data line from the I ² C bus to the on board Microcontroller. 100kbps max. data rate.
SCL ^b	-	-	-	-	LVTTTL, open collector serial clock line from the I ² C bus to the on board Microcontroller.
Reset hold ^c	30	-	-	ms	LVTTTL input, internal 50kΩ pull-up. Active Low

^a I²C SDA and SCL must be open collector or open drain connections.

^b Clock stretching, as per paragraph 13.2 of the I²C Bus Standard, must be implemented to operate correctly.

^c Please see Table 6 and the timing diagram in Figure 2 below for the recommended system start-up sequence.

Table 6 – Suggested Start-up Sequence

Step	Action
1	Power up the host system, with the RESET pin pulled to ground via a $\leq 4.7k\Omega$ resistor.
2	Drive the RESET pin LOW.
3	Ensure power to the unit is on.
4	Drive the RESET pin HIGH to release the unit to become operational.
5	Read byte A2.6E several times. There will be a NACK until the processor is booted, followed by a 01 (DATA READY BAR) until the A2D data is ready, followed by 00 (assuming TXDIS and TXFAIL are inactive).
6	The unit is now ready for normal operation.

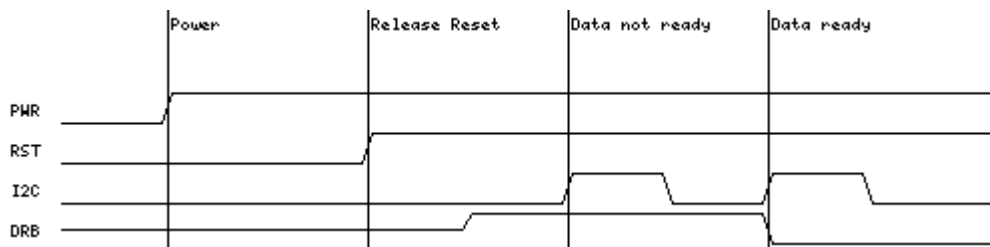

Figure 2 - Recommended transceiver module start-up sequence

2x5 Pin Definitions

Refer to Table 7 for a description of the function of each I/O pin.

Table 7 - Module Pin Definitions

Pin Number	Label	Definition
1	GND_RX	Digital Rx Ground
2	Vcc_RX	Digital Rx Vcc
3	SD	Signal Detect output, pull up internally. Asserts high when input optical power level is above threshold
4	RxD-	RX data bar output, CML. 50Ω terminated to Vcc and AC coupled to module output (0.1μF)
5	RxD+	RX data output, CML. 50Ω terminated to Vcc and AC coupled to module output (0.1μF)
6	Vcc_TX	Digital Tx Vcc
7	GND_TX	Digital Tx Ground
8	TX_ENB	Tx Burst Enable, LVTTTL Input
9	TxD+	Tx data input, CML. Internally DC coupled. 100Ω differential termination.
10	TxD-	Tx data bar input, CML. Internally DC coupled. 100Ω differential termination.

2x10 Pin Definitions

Refer to Table 8 for a description of the function of each I/O pin.

Table 8 - Module Pin Definitions

Pin Number	Label	Definition
1	NC	No User Connection
2	GND_RX	Digital Rx ground
3	GND_RX	Digital Rx ground
4	NC	Reserved, No User Connection
5	NC	Reserved, No User Connection
6	GND_RX	Digital Rx Ground
7	Vcc_RX	Digital Rx Vcc
8	SD	Signal Detect output, pull up internally (4.7kΩ). Asserts high when input optical power level is above threshold
9	RxD-	RX data bar output, CML. 50Ω terminated to Vcc and AC coupled to module output (0.1μF)
10	RxD+	RX data output, CML. 50Ω terminated to Vcc and AC coupled to module output (0.1μF)
11	Vcc_TX	Digital Tx Vcc
12	GND_TX	Digital Tx Ground
13	TX_ENB	Tx Burst Enable, LVTTTL Input. Active high.
14	TxD+	Tx data input, CML. Internally DC coupled. 100Ω differential termination.
15	TxD-	Tx data bar input, CML. Internally DC coupled. 100Ω differential termination.
16	GND_TX	Digital Tx Ground
17	SCL	I2C Clock input
18	SDA	I2C Data input/output
19	Reset	Module (Micro-Controller Unit) Reset. LVTTTL. Internal 10kΩ pull up. Active low. The laser TX is disabled when RESET is LOW.
20	GND_TX	Digital TX Ground

SFF 2x5 Package Diagram

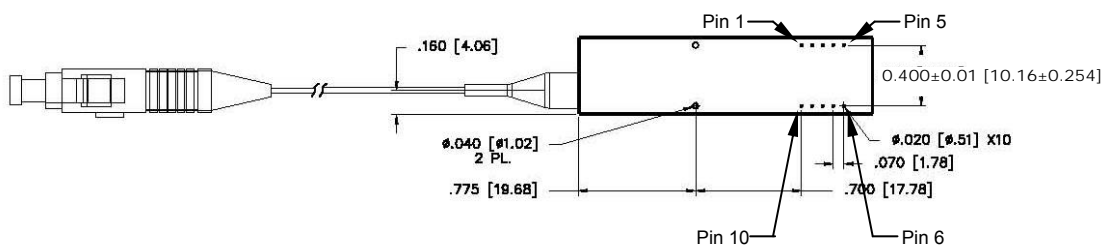

Bottom View

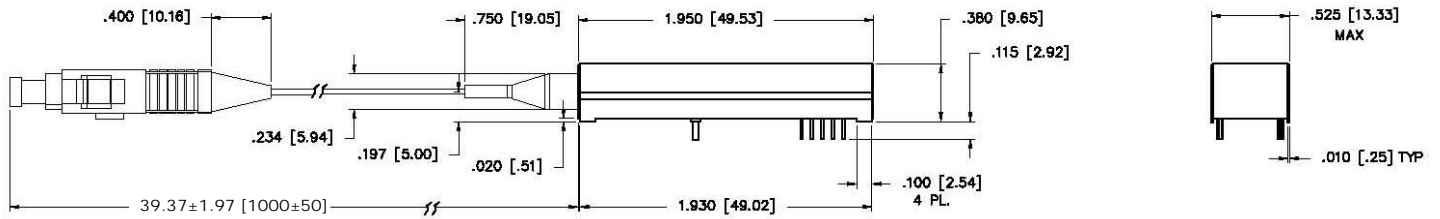

SFF 2x10 Package Diagram

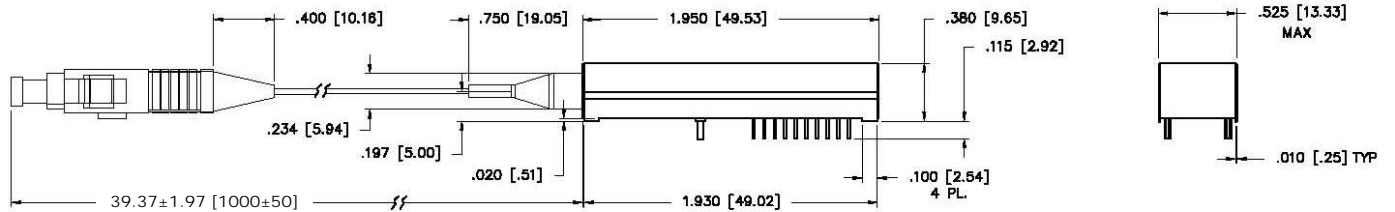
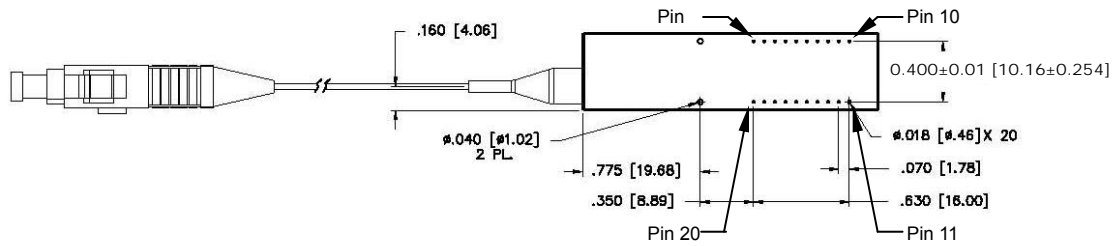

Ordering Information

Table 9 - Ordering Information

Form Factor	dash	Wavelengths-	dash	DataRate Tx (Mb/s)	Data Rate Rx (Mb/s)	dash	Interface (Standard or Luminant Specified)	dash	Temperature range	X	X	dash	Customer Specific
SXY	-	TR	-	FE = Fast	blank = symmetric	-	BX	-	C = commercial		design revision	-	blank = standard Labelling, serial number, or shipping instructions etc.
X= P (plugable small form)		T= transmit wavelength		GB = GbE	F= four times		LX		T = industrial Temp (-40 to 85)	D= diagnostic	X= letter		
X= F (through hole small form 2x10; 2x5)		R = Receive Wavelength		03 = 155	T= twice		P1=PX10		R = reduced Industrial Temp (-20 to 85)	N= no diagnostic			
X=T (2X15 footprint)		3= 1310		12 = 622	H= half		P2 = PX20						
Y= L (LC)		4= 1490		24 = 1244	Q= quarter		AP = GPON class A						
Y= S (SC)		5 = 1550		48 = 2488	E= eighth		BP = BPON Class B						
Y= A (pigtailSC)				FC = Fibre	S= sixteenth		GP = GPON Class B						
Y= U (pigtail UPC)				2F = 2x Fibre			HP = GPON Class B+						
				4F = 4x Fibre			FP = GPON FP/PIN						

Table 10 - Device Handling/ESD Protection

The devices are static sensitive and may easily be damaged if care is not taken during handling. The following handling practices are recommended.

1	Devices should be handled on benches with conductive and grounding surfaces.
2	All personnel, test equipment and tools shall be grounded.
3	Do not handle the devices by their leads.
4	Store devices in protective foam or carriers.
5	Avoid the use of non-conductive plastics, rubber, or silk in the area where the devices are handled
6	All modules shall be packaged in materials that are anti-static to protect against adverse electrical environments.
7	Avoid applications of any voltage higher than maximum rated voltages to this part. For proper operation, any VIN or VOUT should be constrained to the range $GND \leq (VIN \text{ or } VOUT) \leq VCC$. Unused inputs must always be tied to an appropriate logic voltage (e.g. either GND or VCC). Unused outputs must be left open.

Warnings

Handling Precautions: This device is susceptible to damage as a result of electrostatic discharge (ESD). A static free environment is highly recommended. Follow guidelines according to proper ESD procedures.

Laser Safety: Radiation emitted by laser devices can be dangerous to human eyes. Avoid eye exposure to direct or indirect radiation.

Legal Notice

IMPORTANT NOTICE!

All information contained in this document is subject to change without notice, at Source Photonics' sole and absolute discretion. Source Photonics warrants performance of its products to current specifications only in accordance with the company's standard one-year warranty; however, specifications designated as "preliminary" are given to describe components only, and Source Photonics expressly disclaims any and all warranties for said products, including express, implied, and statutory warranties, warranties of merchantability, fitness for a particular purpose, and non-infringement of proprietary rights. Please refer to the company's Terms and Conditions of Sale for further warranty information.

Source Photonics assumes no liability for applications assistance, customer product design, software performance, or infringement of patents, services, or intellectual property described herein. No license, either express or implied, is granted under any patent right, copyright, or intellectual property right, and Source Photonics makes no representations or warranties that the product(s) described herein are free from patent, copyright, or intellectual property rights. Products described in this document are NOT intended for use in implantation or other life support applications where malfunction may result in injury or death to persons. Source Photonics customers using or selling products for use in such applications do so at their own risk and agree to fully defend and indemnify Source Photonics for any damages resulting from such use or sale.

© **Copyright Source Photonics, Inc. 2007~2008**

All Rights Reserved.

All information contained in this document is subject to change without notice. The products described in this document are NOT intended for use in implantation or other life support applications where malfunction may result in injury or death to persons.

The information contained in this document does not affect or change Source Photonics product specifications or warranties. Nothing in this document shall operate as an express or implied license or indemnity under the intellectual property rights of Source Photonics or third parties. All information contained in this document was obtained in specific environments, and is presented as an illustration. The results obtained in other operating environments may vary.

THE INFORMATION CONTAINED IN THIS DOCUMENT IS PROVIDED ON AN "AS IS" BASIS. In no event will Source Photonics be liable for damages arising directly from any use of the information contained in this document.

Contact

SOURCE PHOTONICS
20550 NORDHOFF ST.
CHATSWORTH, CA 91311

sales@sourcephotonics.com

Tel: 818-773-9044 Fax: 818-576-9486

Or visit our website: <http://www.sourcephotonics.com>