



Features

- Dual data-rate of 1.25Gbps/1.0625Gbps operation
- 850nm VCSEL laser and PIN photodetector
- 550m transmission with 50/125 μ m MMF
- 275m transmission with 62.5/125 μ m MMF
- Standard serial ID information compatible with SFP MSA
- SFP MSA package with duplex LC connector
- +3.3V single power supply
- Operating case temperature: -5~+70°C
- RoHS compliant

Regulatory Compliance

Table 1 - Regulatory Compliance

Parameter	Standard	Compliance
Electrostatic Discharge (ESD) to the Electrical Pins	MIL-STD-883E Method 3015.7	Class 2(>2000 V)
Electrostatic Discharge (ESD) to the Duplex LC Receptacle	IEC 61000-4-2 GR-1089-CORE	Compatible with standards
Electromagnetic Interference (EMI)	FCC Part 15 Class B EN55022 Class B (CISPR 22B) VCCI Class B	Compatible with standards
Immunity	IEC 61000-4-3	Compatible with standards
Laser Eye Safety	FDA 21CFR 1040.10 and 1040.11 EN60950, EN (IEC) 60825-1,2	Compatible with Class I laser product.
RoHS	2002/95/EC 4.1&4.2 2005/747/EC	Compliant with RoHS 6

Absolute Maximum Ratings

Table 2 - Absolute Maximum Ratings

Parameter	Symbol	Min.	Typical	Max.	Unit	Notes
Storage Temperature	T _S	-40	-	+85	°C	
Supply Voltage	V _{CC}	-0.5	-	+3.6	V	
Operating Relative Humidity	RH	+5	-	+95	%	

Recommended Operating Conditions

Table 3 – Recommended Operating Conditions

Parameter		Symbol	Min.	Typical	Max.	Unit	Notes
Operating Case Temperature		T_C	-5	-	+70	°C	
Power Supply Voltage		V_{CC}	3.13	3.3	3.47	V	
Power Supply Current		I_{CC}	-		300	mA	
Power Dissipation		P_D	-	-	1	W	
Data Rate	Gigabit Ethernet			1.25		Gbps	
	Fibre Channel			1.0625			

Optical Characteristics

Table 4 – Optical Characteristics

Transmitter								
Parameter		Symbol	Min.	Typical	Max.	Unit	Notes	
Centre Wavelength		λ_C	830	850	860	nm		
Average Output Power		P_{Out}	-9.5		-4	dBm	1	
$P_{Out@TX}$ Disable Asserted		P_{Out}			-30	dBm	1	
Spectral Width (RMS)		σ			0.85	nm		
Extinction Ratio		EX	9			dB		
Rise/Fall Time (20%~80%)		t_r/t_f			0.26	ns	2	
Total Jitter	1.25G	TJ			0.431	UI	3	
	1.0625G				0.43			
Deterministic Jitter	1.25G	DJ			0.2	UI	3	
	1.0625G				0.21			
Output Optical Eye		IEEE 802.3z and ANSI Fibre Channel Compatible						4
Receiver								
Centre Wavelength		λ_C	770		860	nm		
Receiver Sensitivity	1.0625Gbps				-17	dBm	5	
	1.25Gbps				-17	dBm	5	
Receiver Overload			0			dBm		
Return Loss			12			dB		
LOS De-Assert		LOS_D			-18	dBm		
LOS Assert		LOS_A	-30			dBm		
LOS Hysteresis			0.5		4	dB		
Total Jitter (pk-pk)	1.25G	TJ			0.749	UI	3	
	1.0625G				0.61			
Deterministic Jitter (pk-pk)	1.25G	DJ			0.462	UI	3	
	1.0625G				0.36			

Notes:

1. The optical power is launched into MMF.
2. Unfiltered, measured with a PRBS 2^7-1 test pattern @1.25Gbps
3. Meet the specified maximum output jitter requirements if the specified maximum input jitter is present.
4. Measured with a PRBS 2^7-1 test pattern @1.25Gbps/1.0625Gbps.
5. Measured with a PRBS 2^7-1 test pattern @1.25Gbps, extinction ratio ER=9dB, BER $\leq 1 \times 10^{-12}$

Receiver Sensitivity is -17 dBm with following link lengths:

550 m over MMF 50um with bandwidth 500 MHz*Km @ 850nm

500 m over MMF 50um with bandwidth 400 MHz*Km @ 850nm

275 m over MMF 62.5um with bandwidth 200 MHz*Km @ 850nm

220 m over MMF 62.5um with bandwidth 160 MHz*Km @ 850nm

Electrical Characteristics

Table 5 – Electrical Characteristics

Transmitter						
Parameter	Symbol	Min.	Typical	Max.	Unit	Notes
Data Input Swing Differential	V_{IN}	500		2400	mV	1
Input Differential Impedance	Z_{IN}	90	100	110	Ω	
Tx_DIS Disable	V_D	2.0		V_{CC}	V	
Tx_DIS Enable	V_{EN}	GND		GND+0.8	V	
TX_ Fault (Fault)		2.0		Vcc+0.3	V	
TX_ Fault (Normal)		0		0.8	V	
Receiver						
Data Output Swing Differential	V_{OUT}	370		2000	mV	1
Rx_LOS Fault	$V_{LOS-Fault}$	2.0		Vcc+0.3	V	
Rx_LOS Normal	$V_{LOS-Normal}$	GND		GND+0.8	V	

Notes:

1. Internally AC coupled

Recommended Host Board Power Supply Circuit

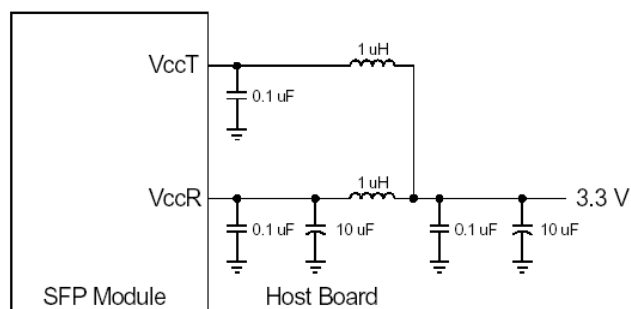

Figure 1, Recommended Host Board Power Supply Circuit

Recommended Interface Circuit

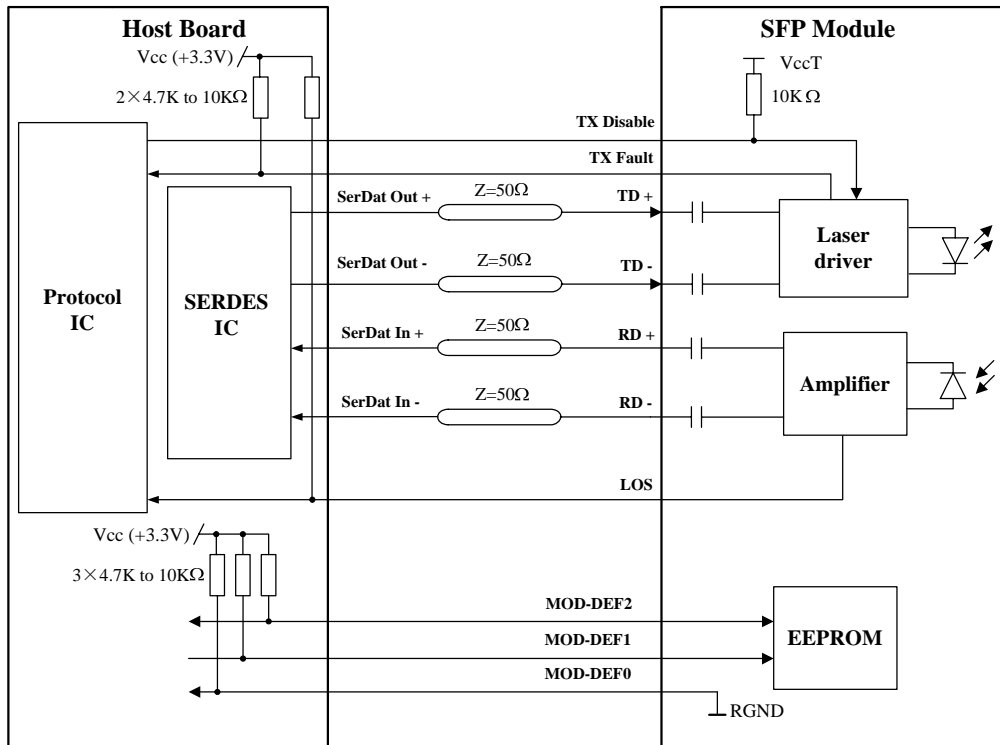

Figure 2, Recommended Interface Circuit

Pin Definitions

Figure 3 below shows the pin numbering of SFP electrical interface. The pin functions are described in Table 6 with some accompanying notes.

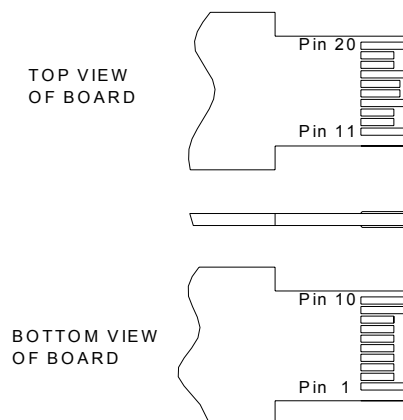

Figure 3, Pin View

Table 6 - Pin Function Definitions

Pin No.	Name	Function	Plug Seq.	Notes
1	VeeT	Transmitter Ground	1	
2	TX Fault	Transmitter Fault Indication	3	Note 1
3	TX Disable	Transmitter Disable	3	Note 2

4	MOD-DEF2	Module Definition 2	3	Note 3
5	MOD-DEF1	Module Definition 1	3	Note 3
6	MOD-DEF0	Module Definition 0	3	Note 3
7	Rate Select	Not Connected	3	
8	LOS	Loss of Signal	3	Note 4
9	VeeR	Receiver Ground	1	
10	VeeR	Receiver Ground	1	
11	VeeR	Receiver Ground	1	
12	RD-	Inv. Received Data Out	3	Note 5
13	RD+	Received Data Out	3	Note 5
14	VeeR	Receiver Ground	1	
15	VccR	Receiver Power	2	
16	VccT	Transmitter Power	2	
17	VeeT	Transmitter Ground	1	
18	TD+	Transmit Data In	3	Note 6
19	TD-	Inv. Transmit Data In	3	Note 6
20	VeeT	Transmitter Ground	1	

Notes:

- TX Fault is an open collector output, which should be pulled up with a 4.7k~10kΩ resistor on the host board to a voltage between 2.0V and Vcc+0.3V. Logic 0 indicates normal operation; logic 1 indicates a laser fault of some kind. In the low state, the output will be pulled to less than 0.8V.
- TX Disable is an input that is used to shut down the transmitter optical output. It is pulled up within the module with a 4.7k~10kΩ resistor. Its states are:
 Low (0~0.8V): Transmitter on
 (>0.8V, <2.0V): Undefined
 High (2.0~3.465V): Transmitter Disabled
 Open: Transmitter Disabled
- MOD-DEF 0,1,2 are the module definition pins. They should be pulled up with a 4.7k~10kΩ resistor on the host board. The pull-up voltage shall be VccT or VccR.
 MOD-DEF 0 is grounded by the module to indicate that the module is present
 MOD-DEF 1 is the clock line of two wires serial interface for serial ID
 MOD-DEF 2 is the data line of two wires serial interface for serial ID
- LOS is an open collector output, which should be pulled up with a 4.7k~10kΩ resistor on the host board to a voltage between 2.0V and Vcc+0.3V. Logic 0 indicates normal operation; logic 1 indicates loss of signal. In the low state, the output will be pulled to less than 0.8V.
- These are the differential receiver output. They are internally AC-coupled 100Ω differential lines which should be terminated with 100Ω (differential) at the user SERDES.
- These are the differential transmitter inputs. They are AC-coupled, differential lines with 100Ω differential termination inside the module.

EEPROM Information

The SFP MSA defines a 256-byte memory map in EEPROM describing the transceiver's capabilities, standard

interfaces, manufacturer, and other information, which is accessible over a 2 wire serial interface at the 8-bit address 1010000X (A0h). The memory contents refer to Table 7.

Table 7 - EEPROM Serial ID Memory Contents (A0h)

Addr.	Field Size (Bytes)	Name of Field	Hex	Description
0	1	Identifier	03	SFP
1	1	Ext. Identifier	04	MOD4
2	1	Connector	07	LC
3—10	8	Transceiver	00 00 00 01 20 40 0C 01	Transmitter Code
11	1	Encoding	01	8B10B
12	1	BR, nominal	0D	1.25Gbps
13	1	Reserved	00	
14	1	Length (9um)-km	00	
15	1	Length (9um)	00	
16	1	Length (50um)	37	550m
17	1	Length (62.5um)	1B	270m
18	1	Length (copper)	00	
19	1	Reserved	00	
20—35	16	Vendor name	53 4F 55 52 43 45 50 48 4F 54 4F 4E 49 43 53 20	"SOURCEPHOTONICS"(ASC II)
36	1	Reserved	00	
37—39	3	Vendor OUI	00 1F 22	
40—55	16	Vendor PN	53 50 47 42 53 58 43 4E 46 42 20 20 20 20 20 20	"SPGBSXCNFB" (ASC II)
56—59	4	Vendor rev	31 30 20 20	ASC II ("31 30 20 20" means 1.0 revision)
60-61	2	Wavelength	03 52	850nm
62	1	Reserved	00	
63	1	CC BASE	xx	Check sum of bytes 0 - 62
64—65	2	Options	00 1A	LOS, TX_FAULT and TX_DISABLE
66	1	BR, max	00	
67	1	BR, min	00	
68—83	16	Vendor SN	xx xx xx xx xx xx xx xx xx xx xx xx xx xx xx xx	ASC II
84—91	8	Vendor date code	xx xx xx xx xx xx 20 20	Year(2 byte), Month(2 byte), Day (2 byte)
92—94	3	Reserved	00 00 00	
95	1	CC EXT	xx	Check sum of bytes 64 - 94
96—255	160	Vendor specific		

Note: The "xx" byte should be filled in according to practical case. For more information, please refer to the related document of SFP Multi-Source Agreement (MSA).

Mechanical Diagram

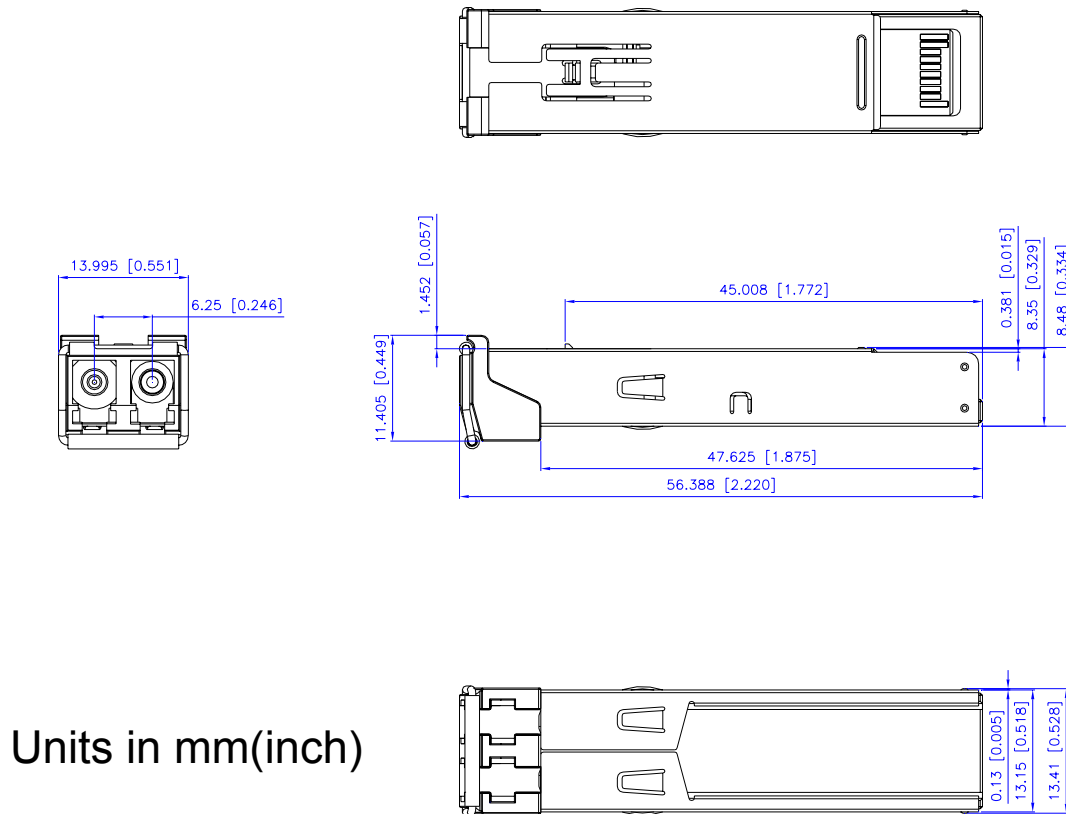

Units in mm(inch)

Figure 5, Mechanical Design Diagram of the SFP

Order Information

Table 9 – Order Information

Part No.	Application	Data Rate	Laser Source	Fiber Type
SP-GB-SX-CNFB	1000BASE-SX	1.25Gbps	850nm VCSEL	MMF

Warnings

Handling Precautions: This device is susceptible to damage as a result of electrostatic discharge (ESD). A static free environment is highly recommended. Follow guidelines according to proper ESD procedures.

Laser Safety: Radiation emitted by laser devices can be dangerous to human eyes. Avoid eye exposure to direct or indirect radiation.

Legal Notice

IMPORTANT NOTICE!

All information contained in this document is subject to change without notice, at Source Photonics's sole and

absolute discretion. Source Photonics warrants performance of its products to current specifications only in accordance with the company's standard one-year warranty; however, specifications designated as "preliminary" are given to describe components only, and Source Photonics expressly disclaims any and all warranties for said products, including express, implied, and statutory warranties, warranties of merchantability, fitness for a particular purpose, and non-infringement of proprietary rights. Please refer to the company's Terms and Conditions of Sale for further warranty information.

Source Photonics assumes no liability for applications assistance, customer product design, software performance, or infringement of patents, services, or intellectual property described herein. No license, either express or implied, is granted under any patent right, copyright, or intellectual property right, and Source Photonics makes no representations or warranties that the product(s) described herein are free from patent, copyright, or intellectual property rights. Products described in this document are NOT intended for use in implantation or other life support applications where malfunction may result in injury or death to persons. Source Photonics customers using or selling products for use in such applications do so at their own risk and agree to fully defend and indemnify Source Photonics for any damages resulting from such use or sale.

THE INFORMATION CONTAINED IN THIS DOCUMENT IS PROVIDED ON AN "AS IS" BASIS. Customer agrees that Source Photonics is not liable for any actual, consequential, exemplary, or other damages arising directly or indirectly from any use of the information contained in this document. Customer must contact Source Photonics to obtain the latest version of this publication to verify, before placing any order, that the information contained herein is current.

Contact

U.S.A. Headquarters

20550 Nordhoff Street
Chatsworth, CA 91311
USA
Tel: +1-818-773-9044
Fax: +1-818-773-0261

China

Building #2&5, West Export
Processing Zone
No. 8 Kexin Road, Hi-Tech Zone
Chengdu, 611731, China
Tel: +86-28-8795-8788
Fax: +86-28-8795-8789

Taiwan

9F, No 81, Shui Lee Rd.
Hsinchu, Taiwan, R.O.C.
Tel: +886-3-5169222
Fax: +886-3-5169213

© Copyright Source Photonics, Inc. 2007~2008

All rights reserved