

Features



- Up to 1.25Gbps bi-direction data links
- 100m transmission over unshielded twisted-pair (UTP) Category 5 Cable
- 10/100/1000BASE-T operation in host systems with SGMII interface
- Hot-pluggable capability
- SFP form with compact RJ-45 connector
- With spring latch for high density application
- Very low EMI and excellent ESD protection
- +3.3V single power supply
- Low power dissipation
- Operating case temperature: -5 to +70°C
- Detailed product information in EEPROM
- Physical layer IC can be accessed via 2-wire serial bus

Regulatory Compliance

Table 1 - Regulatory Compliance

Feature	Standard	Performance
Electrostatic Discharge (ESD) to the Electrical Pins	MIL-STD-883E Method 3015.7	Class 2(>2000 V)
Electrostatic Discharge (ESD) to the RJ-45 Receptacle	IEC 61000-4-2 GR-1089-CORE	Compatible with standards
Electromagnetic Interference (EMI)	FCC Part 15 Class B EN55022 Class B (CISPR 22B) VCCI Class B	Compatible with standards
Immunity	IEC 61000-4-3	Compatible with standards
Component Recognition	UL and CSA	Compatible with standards
RoHS	2002/95/EC 4.1&4.2	Compliant with standards

Absolute Maximum Ratings

Table 2 - Absolute Maximum Ratings

Parameter	Symbol	Min.	Typical	Max.	Unit	Notes
Storage Temperature	T _s	-40	-	+85	°C	
Supply Voltage	V _{CC}	-0.5	-	+3.6	V	
Operating Relative Humidity	RH	5	-	+95	%	

Recommended Operating Conditions

Table 3 – Recommended Operating Conditions

Parameter	Symbol	Min.	Typical	Max.	Unit	Notes
Operating Case Temperature	T _C	-5	-	+70	°C	
Power Supply Voltage	V _{CC}	3.13	3.30	3.47	V	
Power Supply Current	I _{CC}	-	325	385	mA	1
Date Rate		10		1000	Mbps	2

Note 1: The max. power supply current after module work stable.

2: 10/100/1000 BASE-T operation requires an SGMII interface with no clocks in the host system, and the module will operate as 1000BASE-T when the host system uses SERDES interface.

Host Side Electrical Interface

Table 4 –Electrical Characteristics

Transmitter						
Parameter	Symbol	Min.	Typical	Max.	Unit	Notes
Data Input Swing Differential	V _{IN}	250		1200	mV	1
Input Differential Impedance	Z _{IN}		100		Ω	
PHY Reset	Reset	2.0		V _{CC}	V	
	Normal	V _{EE}		V _{EE} +0.8	V	
Data Output Swing Differential	V _{OUT}	350		800	mV	2
Output Differential Impedance	Z _{OUT}		100		Ω	
Output Data Rise/Fall Time	Tr/Tf		175		ps	

Notes:

- Internally AC coupled and terminated.
- Internally AC coupled.

Line Side Electrical Interface

Table 5 – Electrical Characteristics

Transmitter						
Parameter	Symbol	Min.	Typical	Max.	Unit	Notes
Line Baud Rate			125		MBaud	1
Bit Error Rate	BER			10^{-12}		2
Line Rx Input Impedance	Z_{IN}		100		Ω	
Line Tx Output Impedance	Z_{OUT}		100		Ω	

Notes:

1. Measured over 100m Cat-5 UTP cable.
2. Measured over 100m Cat-5 UTP cable.

Recommended Host Board Power Supply Circuit

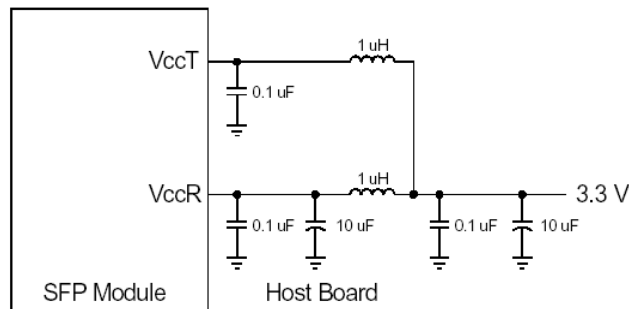
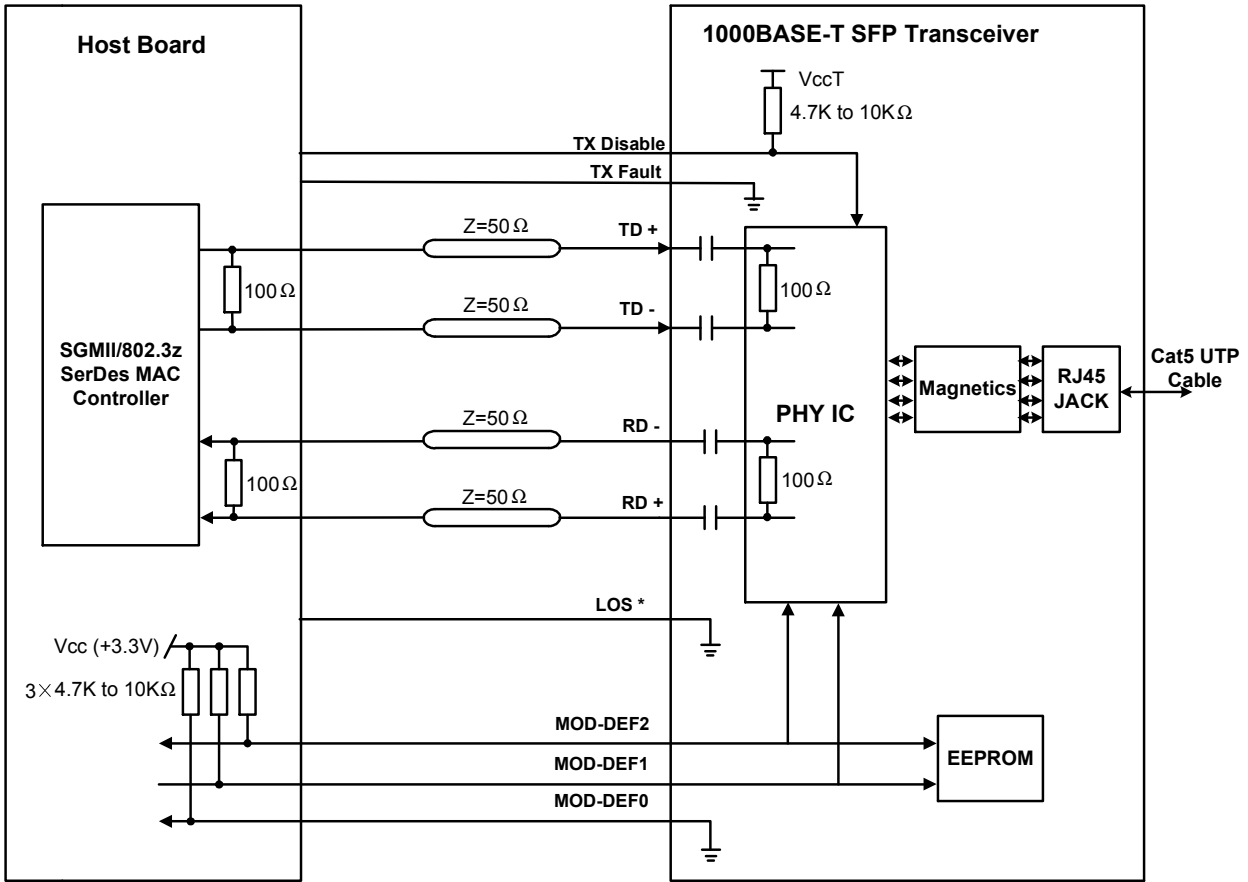

Figure 1, Recommended Host Board Power Supply Circuit

Recommended Interface Circuit



* NOTE. About the LOS, please refer to the section of 20-pin definition

Figure 2, Recommended Host Board Power Supply Circuit

Pin Definitions

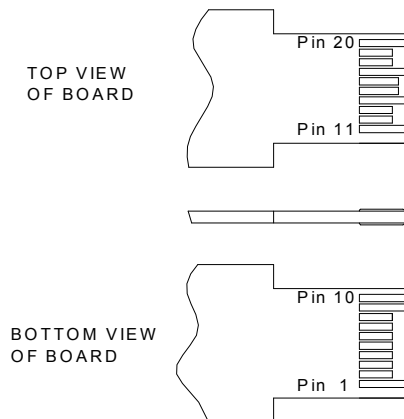

Figure 3, Pin View

Table 6–Pin Function Definitions

Pin No.	Name	Function	Plug Seq.	Notes
1	VeeT	Transmitter Ground	1	
2	TX Fault	Transmitter Fault Indication	3	Note 1
3	TX Disable	Transmitter Disable	3	Note 2
4	MOD-DEF2	Module Definition 2	3	Note 3
5	MOD-DEF1	Module Definition 1	3	Note 3
6	MOD-DEF0	Module Definition 0	3	Note 3
7	Rate Select	Not Connected	3	
8	LOS	Loss of Signal	3	Note 4
9	VeeR	Receiver Ground	1	
10	VeeR	Receiver Ground	1	
11	VeeR	Receiver Ground	1	
12	RD-	Inv. Received Data Out	3	Note 5
13	RD+	Received Data Out	3	Note 5
14	VeeR	Receiver Ground	1	
15	VccR	Receiver Power	2	
16	VccT	Transmitter Power	2	
17	VeeT	Transmitter Ground	1	
18	TD+	Transmit Data In	3	Note 6
19	TD-	Inv. Transmit Data In	3	Note 6
20	VeeT	Transmitter Ground	1	

Notes:

- TX Fault is an open collector output, which should be pulled up with a 4.7k~10kΩ resistor on the host board to a voltage between 2.0V and Vcc+0.3V. Logic 0 indicates normal operation; logic 1 indicates a laser fault of some kind. In the low state, the output will be pulled to less than 0.8V.
- TX Disable is an input that is used to shut down the transmitter optical output. It is pulled up within the module with a 4.7k~10kΩ resistor. Its states are:
 - Low (0~0.8V): Transmitter on
 - (>0.8V, <2.0V): Undefined
 - High (2.0~3.465V): Transmitter Disabled
 - Open: Transmitter Disabled
- MOD-DEF 0,1,2 are the module definition pins. They should be pulled up with a 4.7k~10kΩ resistor on the host board. The pull-up voltage shall be VccT or VccR.
 MOD-DEF 0 is grounded by the module to indicate that the module is present
 MOD-DEF 1 is the clock line of two wire serial interface for serial ID
 MOD-DEF 2 is the data line of two wire serial interface for serial ID
- LOS is an open collector output, which should be pulled up with a 4.7k~10kΩ resistor on the host board to a voltage between 2.0V and Vcc+0.3V. Logic 0 indicates normal operation; logic 1 indicates loss of signal or link down with partner I. In the low state, the output will be pulled to less than 0.8V.
- These are the differential receiver output. They are internally AC-coupled 100Ω differential lines which

should be terminated with 100Ω (differential) at host with SGMII interface.

6. These are the differential transmitter inputs. They are AC-coupled, differential lines with 100Ω differential termination inside the module.

EEPROM Information

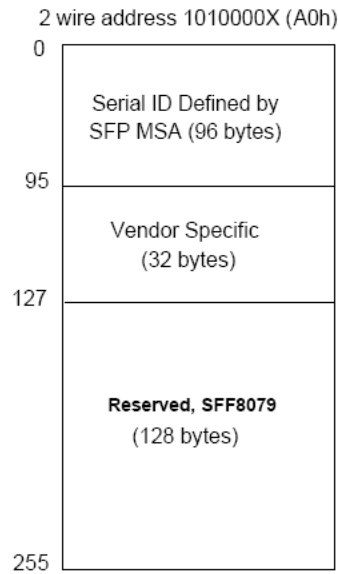

Figure 4, 2-wire Serial Memory Map

Table 7 –EEPROM Serial ID Memory Contents (A0h)

Addr.	Field Size (Bytes)	Name of Field	Hex	Description
0	1	Identifier	03	SFP
1	1	Ext. Identifier	04	MOD4
2	1	Connector	00	LC
3—10	8	Transceiver	00 00 00 08 00 00 00 00	1000BASE-T
11	1	Encoding	01	8B10B
12	1	BR, nominal	0D	1.25G
13	1	Reserved	00	
14	1	Length (9um)-km	00	
15	1	Length (9um)	00	
16	1	Length (50um)	00	
17	1	Length (62.5um)	00	
18	1	Length (copper)	64	100m
19	1	Reserved	00	
20—35	16	Vendor name	53 4F 55 52 43 45 50 48 4F 54 4F 4E 49 43 53 20	“SOURCEPHOTONICS“(ASC II)

36	1	Reserved	00	
37—39	3	Vendor OUI	00 00 00	
40—55	16	Vendor PN	53 50 47 42 54 58 43 4E 46 xx 20 20 20 20 20 20	“SPGBTXCNFx” (ASC II)
56—59	4	Vendor rev	31 30 20 20	ASC II (“31 30 20 20” means 1.0 revision)
60-61	2	Wavelength	00 00	
62	1	Reserved	00	
63	1	CC BASE	xx	Check sum of bytes 0 - 62
64—65	2	Options	00 00	
66	1	BR, max	00	
67	1	BR, min	00	
68—83	16	Vendor SN	xx xx xx xx xx xx xx xx xx xx xx xx xx xx xx xx	ASC II .
84—91	8	Vendor date code	xx xx xx xx xx xx 20 20	Year (2 bytes), Month (2 bytes), Day (2 bytes)
92	1	Reserved	00	
93	1	Reserved	00	
94	1	Reserved	00	
95	1	CC_EXT	xx	Check sum of bytes 64 - 94
96—255	160	Vendor specific		

Note: The “xx” byte should be filled in according to practical case. For more information, please refer to the related document of SFP MSA.

Recommended Software configuration

How to enable SP-GB-TX-CNFM/D work at 10/100/1000BASE-T

SP-GB-TX-CNFM/D supports 1000Mbps full duplex SerDes interface default. But it also can operate with SGMII (without clocks) interface by software configuration when HOST is SGMII interface.

Please refer the following steps to configure:

Step 1: Access the PHY at 0xAC via two-wire serial interface.

Step 2: Configure 0xAC as below table

PHY Address: 0xAC		
Register Address	Write data	Description
0x1Bh	0x9084h	Enable SGMII mode
0x00h	0x9140h	Software reset to allow changes to take effect
0x16h	0x0000	Select page 0
0x09h	0x0F00h	Advertise 1000BASE-T FD/HD
0x04h	0x0DE1h	Advertise 100/10BASE-T FD/HD
0x00h	0x9140h	Software reset to allow changes to take effect

Notes:

FD: Full Duplex

HD: Half Duplex

How to enable SP-GB-TX-CNFC work at 1000BASE-T

SP-GB-TX-CNFC supports 10/100/1000Mbps full duplex SGMII interface default. But it also can operate with 1000Mbps of SERDES operation.

Please refer the following steps to configure:

Step 1: Access the PHY at 0xAC via two-wire serial interface.

Step 2: Configure 0xAC as below table

PHY Address: 0xAC		
Register Address	Write data	Description
0x16	0x0001	Select page 1
0x1B	0x9088	Enable SerDes mode
0x00	0x9140	Software reset to allow changes to take effect
0x16	0x0000	Select page 0

How to disable Auto-negotiation on SP-GB-TX-CNFC/M

SP-GB-TX-CNFC/M work at mode of “Auto-negotiation enable” default. But it also can operate with “Auto-negotiation disable”. Please refer the following steps to configure:

Step 1: Access the PHY at 0xAC via two-wire serial interface.

Step 2: Configure 0xAC as below table

PHY Address: 0xAC		
Register Address	Write data	Description
0x16h	0x0001h	Select page 1
0x00h	0x8140h	Disable Auto-negotiation
0x16h	0x0000h	Select page 0

How to enable Auto-negotiation on SP-GB-TX-CNFD

SP-GB-TX-CNFD work at mode of “Auto-negotiation disable” default. But it also can operate with “Auto-negotiation enable”. Please refer the following steps to configure:

Step 1: Access the PHY at 0xAC via two-wire serial interface.

Step 2: Configure 0xAC as below table

PHY Address: 0xAC		
Register Address	Write data	Description
0x16h	0x0001h	Select page 1
0x00h	0x9140h	Enable Auto-negotiation
0x16h	0x0000h	Select page 0

To get more detailed information about above configuration, please contact Source Photonics, Inc. America Sales Office listed at the end of documentation to get the relevant Application Notes.

Mechanical Diagram

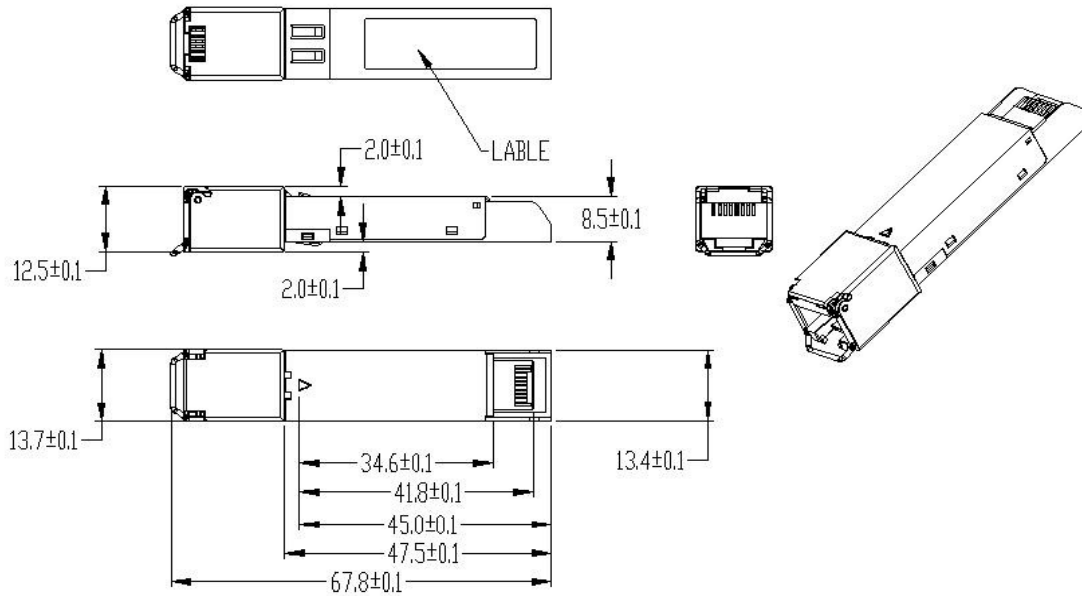

Figure 5, Mechanical Diagram

Order Information

Table 8 – Order Information

Part No.	Media	Data Rate(Mbps)	Transmission Distance(km)	Temperature
SP-GB-TX-CNFD	unshielded twisted-pair (UTP) Category 5 Cable	1000BASE-T, with SERDES interface, disable the auto-negotiation default, support Rx_LOS as link indication function,	0.1	-5~+70°C
SP-GB-TX-CNFM	unshielded twisted-pair (UTP) Category 5 Cable	1000BASE-T, with SERDES interface, enable the auto-negotiation default,	0.1	-5~+70°C
SP-GB-TX-CNFC	unshielded twisted-pair (UTP) Category 5 Cable	10/100/1000Mbps, with SGMII interface, enable the auto-negotiation default,	0.1	-5~+70°C

Warnings

Handling Precautions: This device is susceptible to damage as a result of electrostatic discharge (ESD). A static free environment is highly recommended. Follow guidelines according to proper ESD procedures.

Laser Safety: Radiation emitted by laser devices can be dangerous to human eyes. Avoid eye exposure to direct or indirect radiation.

Legal Notice

IMPORTANT NOTICE!

All information contained in this document is subject to change without notice, at Source Photonics's sole and absolute discretion. Source Photonics warrants performance of its products to current specifications only in accordance with the company's standard one-year warranty; however, specifications designated as "preliminary" are given to describe components only, and Source Photonics expressly disclaims any and all warranties for said products, including express, implied, and statutory warranties, warranties of merchantability, fitness for a particular purpose, and non-infringement of proprietary rights. Please refer to the company's Terms and Conditions of Sale for further warranty information.

Source Photonics assumes no liability for applications assistance, customer product design, software performance, or infringement of patents, services, or intellectual property described herein. No license, either express or implied, is granted under any patent right, copyright, or intellectual property right, and Source Photonics makes no representations or warranties that the product(s) described herein are free from patent, copyright, or intellectual property rights. Products described in this document are NOT intended for use in implantation or other life support applications where malfunction may result in injury or death to persons. Source Photonics customers using or selling products for use in such applications do so at their own risk and agree to fully defend and indemnify Source Photonics for any damages resulting from such use or sale.

THE INFORMATION CONTAINED IN THIS DOCUMENT IS PROVIDED ON AN "AS IS" BASIS. Customer agrees that Source Photonics is not liable for any actual, consequential, exemplary, or other damages arising directly or indirectly from any use of the information contained in this document. Customer must contact Source Photonics to obtain the latest version of this publication to verify, before placing any order, that the information contained herein is current.

Contact

U.S.A. Headquarters

20550 Nordhoff Street
Chatsworth, CA 91311
USA
Tel: +1-818-773-9044
Fax: +1-818-773-0261

China

Building #2&5, West Export Processing Zone
No. 8 Kexin Road, Hi-Tech Zone
Chengdu, 611731, China
Tel: +86-28-8795-8788
Fax: +86-28-8795-8789

Taiwan

9F, No 81, Shui Lee Rd.
Hsinchu, Taiwan, R.O.C.
Tel: +886-3-5169222
Fax: +886-3-5169213