



## Features

- Built-in PHY supporting SGMII Interface
- 100BASE-LX operation
- 1310nm FP laser and PIN photo-detector
- 0.5m~10km transmission with SMF
- Standard serial ID information Compatible with SFP MSA
- SFP MSA package with duplex LC connector
- With Spring-Latch for high density application
- Very low EMI and excellent ESD protection
- +3.3V single power supply
- Operating case temperature: -5 to +70°C

## Regulatory Compliance

**Table 1 - Regulatory Compliance**

Feature	Standard	Performance
Electrostatic Discharge (ESD) to the Electrical Pins	MIL-STD-883E Method 3015.7	Class 1(>500 V)
Electrostatic Discharge (ESD) to the Duplex LC Receptacle	IEC 61000-4-2 GR-1089-CORE	Compatible with standards
Electromagnetic Interference (EMI)	FCC Part 15 Class B EN55022 Class B (CISPR 22B) VCCI Class B	Compatible with standards
Immunity	IEC 61000-4-3	Compatible with standards
Laser Eye Safety	FDA 21CFR 1040.10 and 1040.11 EN60950, EN (IEC) 60825-1,2	Compatible with Class I laser product.
Component Recognition	UL and CSA	Compatible with standards
RoHS	2002/95/EC 4.1&4.2 2005/747/EC	Compliant with standards <sup>note</sup>

**Note:**

In light of item 5 in Annex of 2002/95/EC, "Pb in the glass of cathode ray tubes, electronic components and fluorescent tubes." and item 13 in Annex of 2005/747/EC, "Lead and cadmium in optical and filter glass." ,the two exemptions are being concerned for Source Photonics' transceivers, because Source Photonics' transceivers use glass, which may contain Pb, for components such as lenses, windows, isolators, and other electronic components.

## Absolute Maximum Ratings

**Table 2 - Absolute Maximum Ratings**

Parameter	Symbol	Min.	Typical	Max.	Unit	Notes
Storage Temperature	$T_s$	-40	-	+85	°C	
Supply Voltage	$V_{CC}$	-0.5	-	+3.6	V	
Operating Relative Humidity	RH	5	-	+95	%	

## Recommended Operating Conditions

**Table 3 – Recommended Operating Conditions**

Parameter	Symbol	Min.	Typical	Max.	Unit	Notes
Operating Case Temperature	$T_C$	-5	-	+70	°C	
Power Supply Voltage	$V_{CC}$	3.10	3.3	3.50	V	
Power Supply Current	$I_{CC}$	-	-	350	mA	1
Date Rate			125		Mbps	

Note 1: The max. power supply current after module work stable.

## Optical Characteristics

**Table 4 – Optical Characteristics**

Transmitter						
Parameter	Symbol	Min.	Typical	Max.	Unit	Notes
Centre Wavelength	$\lambda_c$	1270	1310	1355	nm	
Average Output Power	$P_{out}$	-15		-8	dBm	1
$P_{out}$ @TX Disable Asserted	$P_{out}$			-45	dBm	1
Spectral Width (RMS)	$\sigma$			7.7	nm	
Extinction Ratio	EX	9			dB	
Rise/Fall Time (20%~80%)	$t_r/t_f$			3	ns	2
Output Optical Eye	Compatible with IEEE 802.3ah-2004					3
Receiver						
Centre Wavelength	$\lambda_c$	1260	1310	1570	nm	
Receiver Sensitivity				-28	dBm	4
Receiver Overload		-8			dBm	4
Return Loss		12			dB	
LOS De-Assert	$LOS_D$			-29	dBm	

LOS Assert	LOS <sub>A</sub>	-45			dBm	
LOS Hysteresis		0.5		4.5	dB	
Total Jitter (SGMII Series Interface)	T <sub>J</sub>			0.43	UI	

**Notes:**

1. The optical power is launched into 9/125um SMF.
2. Unfiltered, measured with 4B/5B code for 125Mbps
3. Measured with 4B/5B code for 125Mbps.
4. Measured with 4B/5B code for 125Mbps, worst-case extinction ratio, BER  $\leq 1 \times 10^{-10}$ .

## Electrical Characteristics

**Table 5 – Electrical Characteristics**

Transmitter						
Parameter	Symbol	Min.	Typical	Max.	Unit	Notes
Data Input Swing Differential (SGMII Series interface)	V <sub>IN</sub>	500		1200	mV	1
Input Differential Impedance	Z <sub>IN</sub>	80	100	120	Ω	
TX Disable	Disable		2.0	V <sub>cc</sub>	V	
	Enable		V <sub>ee</sub>	V <sub>ee</sub> +0.8		
TX Fault	Fault		2.0	V <sub>cc</sub>	V	
	Normal		V <sub>ee</sub>	V <sub>ee</sub> +0.5		
Receiver						
Data Output Swing Differential (SGMII Series Interface)	V <sub>OUT</sub>	370		2000	mV	1
LOS	High		2.0	V <sub>cc</sub> +0.3	V	
	Low		V <sub>ee</sub>	V <sub>ee</sub> +0.5		

**Notes:**

1. PECL logic, internally AC coupled.

**Recommended Host Board Power Supply Circuit**

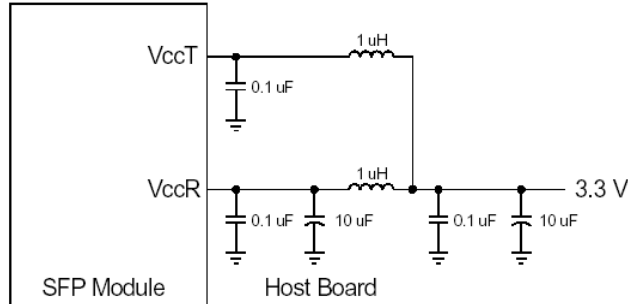

**Figure 1, Recommended Host Board Power Supply Circuit**

**Recommended Interface Circuit**

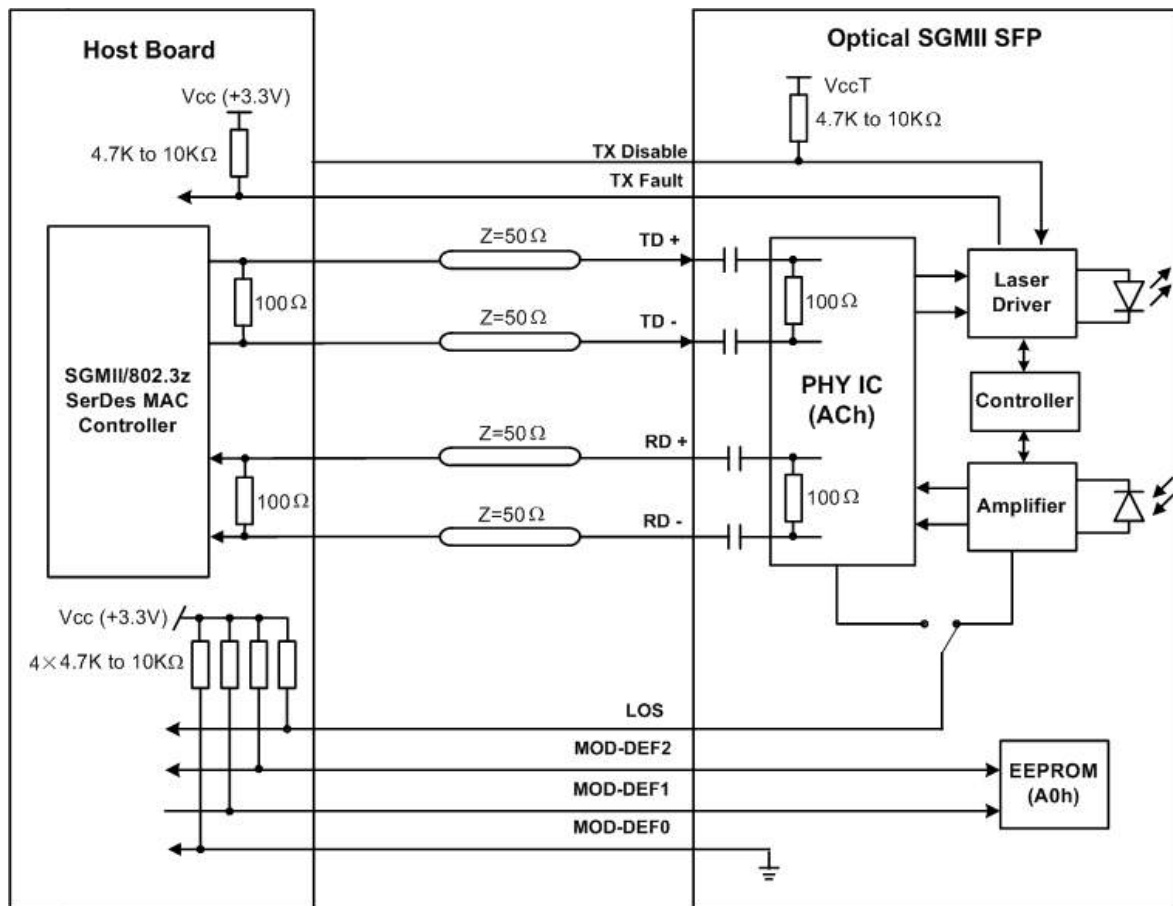

**Figure 2, Recommended Interface Circuit**

## Pin Definitions

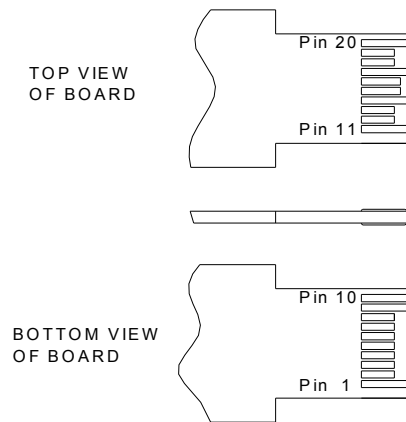

Figure 3, Pin View

Table 6–Pin Function Definitions

Pin No.	Name	Function	Plug Seq.	Notes
1	VeeT	Transmitter Ground	1	
2	TX Fault	Transmitter Fault Indication	3	Note 1
3	TX Disable	Transmitter Disable	3	Note 2
4	MOD-DEF2	Module Definition 2	3	Note 3
5	MOD-DEF1	Module Definition 1	3	Note 3
6	MOD-DEF0	Module Definition 0	3	Note 3
7	Rate Select	Not Connected	3	
8	LOS	Loss of Signal	3	Note 4
9	VeeR	Receiver Ground	1	
10	VeeR	Receiver Ground	1	
11	VeeR	Receiver Ground	1	
12	RD-	Inv. Received Data Out	3	Note 5
13	RD+	Received Data Out	3	Note 5
14	VeeR	Receiver Ground	1	
15	VccR	Receiver Power	2	
16	VccT	Transmitter Power	2	
17	VeeT	Transmitter Ground	1	
18	TD+	Transmit Data In	3	Note 6
19	TD-	Inv. Transmit Data In	3	Note 6
20	VeeT	Transmitter Ground	1	

Notes:

- TX Fault is an open collector output, which should be pulled up with a 4.7k~10kΩ resistor on the host board to a voltage between 2.0V and Vcc+0.3V. Logic 0 indicates normal operation; logic 1 indicates a laser fault of some kind. In the low state, the output will be pulled to less than 0.8V.
- TX Disable is an input that is used to shut down the transmitter optical output. It is pulled up within the

module with a 4.7k~10k $\Omega$  resistor. Its states are:

Low (0~0.8V):	Transmitter on
(>0.8V, <2.0V):	Undefined
High (2.0~3.465V):	Transmitter Disabled
Open:	Transmitter Disabled

3. MOD-DEF 0,1,2 are the module definition pins. They should be pulled up with a 4.7k~10k $\Omega$  resistor on the host board. The pull-up voltage shall be VccT or VccR.  
MOD-DEF 0 is grounded by the module to indicate that the module is present  
MOD-DEF 1 is the clock line of two wire serial interface for serial ID  
MOD-DEF 2 is the data line of two wire serial interface for serial ID
4. LOS is an open collector output, which should be pulled up with a 4.7k~10k $\Omega$  resistor on the host board to a voltage between 2.0V and Vcc+0.3V. Logic 0 indicates normal operation; logic 1 indicates loss of signal or link down with partner I. In the low state, the output will be pulled to less than 0.8V.
5. These are the differential receiver output. They are internally AC-coupled 100 $\Omega$  differential lines which should be terminated with 100 $\Omega$  (differential) at host with SGMII interface.
6. These are the differential transmitter inputs. They are AC-coupled, differential lines with 100 $\Omega$  differential termination inside the module.

## SGMII Interface

SGMII uses two data signals and two clock signals to convey frame data and link rate information between a 100/1000 PHY and an Ethernet MAC. The data signals operate at 1.25 Gbaud and the clocks operate at 625 MHz (a DDR interface). Due to the speed of operation, each of these signals is realized as a differential pair thus providing signal integrity while minimizing system noise.

However, specific implementations may desire to recover clock from the data rather than use the supplied clock, such as in our transceiver design. This operation is allowed.

Clearly, SGMII's 1.25 Gbaud transfer rate is excessive for interfaces operating at 100 Mbps. When these situations occur, the interface "elongates" the frame by replicating each frame byte 10 times for 100 Mbps. This frame elongation takes place "above" the 802.3z PCS layer, thus the start frame delimiter only appears once per frame. The 802.3z PCS layer may remove the first byte of the "elongated" frame. For further information about how to use transceivers with SGMII interface, please refer to the application note.

**EEPROM Information**

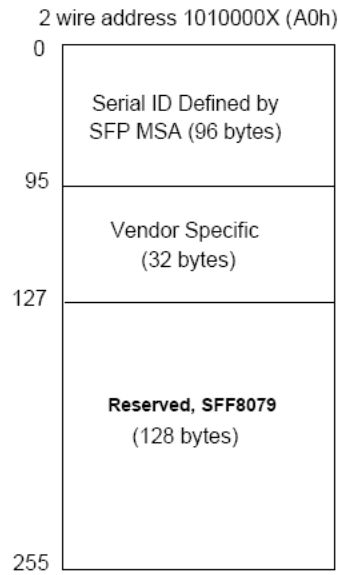

**Figure 4, 2-wire Serial Digital Memory Map**

**Table 7 –EEPROM Serial ID Memory Contents (A0h)**

Addr.	Field Size (Bytes)	Name of Field	Hex	Description
0	1	Identifier	03	SFP
1	1	Ext. Identifier	04	MOD4
2	1	Connector	07	LC
3—10	8	Transceiver	00 00 00 10 00 00 00 00	100BASE-LX
11	1	Encoding	02	4B5B
12	1	BR, nominal	01	100Mbps
13	1	Reserved	00	
14	1	Length (9um)-km	0A	10km
15	1	Length (9um)	64	10000m
16	1	Length (50um)	00	
17	1	Length (62.5um)	00	
18	1	Length (copper)	00	
19	1	Reserved	00	
20—35	16	Vendor name	53 4F 55 52 43 45 50 48 4F 54 4F 4E 49 43 53 20	“SOURCEPHOTONICS “(ASC II)
36	1	Reserved	00	
37—39	3	Vendor OUI	00 00 00	

40—55	16	Vendor PN	53 50 47 46 45 4C 58 43 4E 46 42 20 20 20 20 20	“SPGFELXCNFB” (ASC II)
56—59	4	Vendor rev	31 30 20 20	ASC II ( “31 30 20 20” means 1.0 revision)
60-61	2	Wavelength	05 1E	1310nm
62	1	Reserved	00	
63	1	CC BASE	xx	Check sum of bytes 0 - 62
64—65	2	Options	00 1A	LOS, TX_FAULT and TX_DISABLE
66	1	BR, max	00	
67	1	BR, min	00	
68—83	16	Vendor SN	xx xx xx xx xx xx xx xx xx xx xx xx xx xx xx xx	ASC II .
84—91	8	Vendor date code	xx xx xx xx xx xx 20 20	Year (2 bytes), Month (2 bytes), Day (2 bytes)
92	1	Reserved	00	
93	1	Reserved	00	
94	1	Reserved	00	
95	1	CC_EXT	xx	Check sum of bytes 64 - 94
96—255	160	Vendor specific		

Note: The “xx” byte should be filled in according to practical case. For more information, please refer to the related document of SFP Multi-Source Agreement (MSA).

## Mechanical Diagram

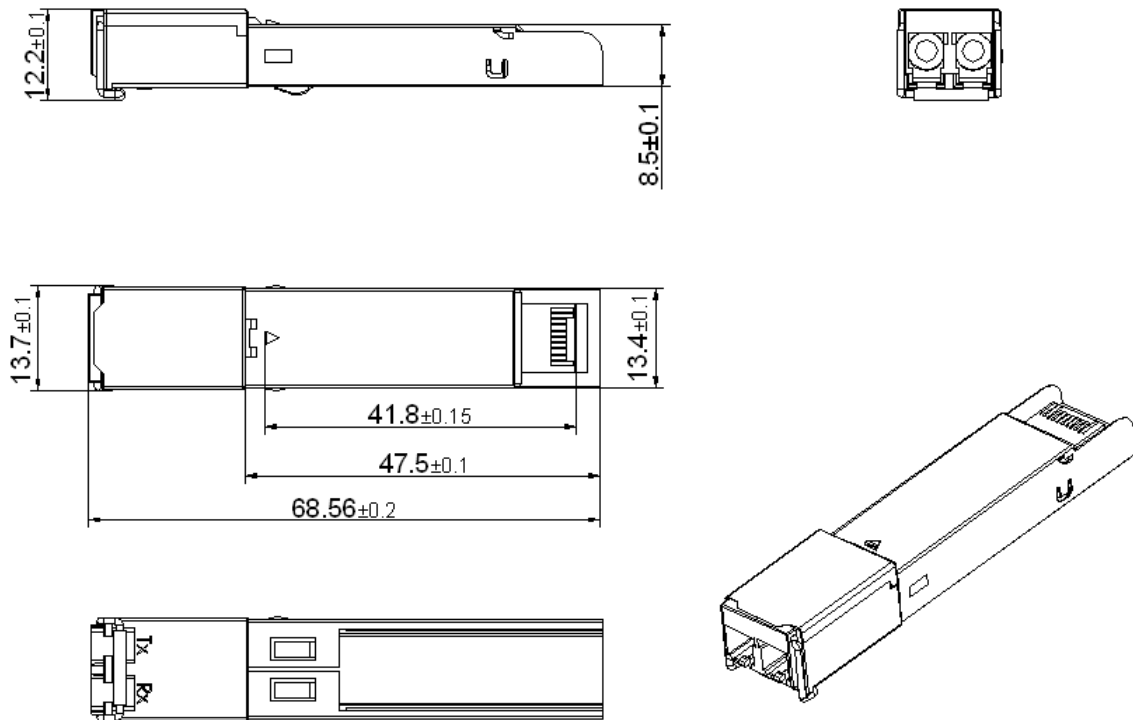

Figure 5, Mechanical Diagram

## Order Information

**Table 8 – Order Information**

Part No.	Media	Data Rate(Mbps)	Transmission Distance(km)	Temperature
SPG-FE-LX-CNFB	SMF	125	10	-5~+70°C

## Warnings

**Handling Precautions:** This device is susceptible to damage as a result of electrostatic discharge (ESD). A static free environment is highly recommended. Follow guidelines according to proper ESD procedures.

**Laser Safety:** Radiation emitted by laser devices can be dangerous to human eyes. Avoid eye exposure to direct or indirect radiation.

## Legal Notice

### IMPORTANT NOTICE!

All information contained in this document is subject to change without notice, at Source Photonics's sole and absolute discretion. Source Photonics warrants performance of its products to current specifications only in accordance with the company's standard one-year warranty; however, specifications designated as "preliminary" are given to describe components only, and Source Photonics expressly disclaims any and all warranties for said products, including express, implied, and statutory warranties, warranties of merchantability, fitness for a particular purpose, and non-infringement of proprietary rights. Please refer to the company's Terms and Conditions of Sale for further warranty information.

Source Photonics assumes no liability for applications assistance, customer product design, software performance, or infringement of patents, services, or intellectual property described herein. No license, either express or implied, is granted under any patent right, copyright, or intellectual property right, and Source Photonics makes no representations or warranties that the product(s) described herein are free from patent, copyright, or intellectual property rights. Products described in this document are NOT intended for use in implantation or other life support applications where malfunction may result in injury or death to persons. Source Photonics customers using or selling products for use in such applications do so at their own risk and agree to fully defend and indemnify Source Photonics for any damages resulting from such use or sale.

THE INFORMATION CONTAINED IN THIS DOCUMENT IS PROVIDED ON AN "AS IS" BASIS. Customer agrees that Source Photonics is not liable for any actual, consequential, exemplary, or other damages arising directly or indirectly from any use of the information contained in this document. Customer must contact Source Photonics to obtain the latest version of this publication to verify, before placing any order, that the information contained herein is current.

## **Contact**

### **U.S.A. Headquarters**

20550 Nordhoff Street  
Chatsworth, CA 91311  
USA

Tel: +1-818-773-9044

Fax: +1-818-773-0261

### **China**

Building #2&5, West Export Processing Zone  
No. 8 Kexin Road, Hi-Tech Zone  
Chengdu, 611731, China

Tel: +86-28-8795-8788

Fax: +86-28-8795-8789

### **Taiwan**

9F, No 81, Shui Lee Rd.  
Hsinchu, Taiwan, R.O.C.

Tel: +886-3-5169222

Fax: +886-3-5169213

© Copyright Source Photonics, Inc. 2007~2008

All rights reserved