

Features

- 1300nm or 1550nm Wavelength
- For Single-mode & Multi-mode Applications
- High Optical Power
- Low Operating Current
- High Speed
- Low Modal Noise
- 8 Pin Package with SC
- High Operating Temperature
- SC type Sugar Cube
- For Data com Measurement Application
- RoHS Compliant available

Absolute Maximum Ratings (Tc=25)

Parameter	Symbol	Condition	Rating	Unit
Reverse Voltage	V _r	CW	2.5	V
Operating Current	I _{op}	CW	150	mA
Operating Temperature	T _{opr}	-	-20 ~ 70	
Storage Temperature	T _{stg}	-	-40 ~ 85	

(All optical data refer to coupled 9/125 μm SM & 50/125 μm MM fiber) Optical and Electrical Characteristics =1300nm (Tc=25)

Parameter	Symbol	Min.	Typ.	Max.	Unit	Notes
Wavelength		1260	1300	1340	nm	CW
Spectral Width		30	-	80	nm	CW
Operating Current	I _{op}	-	80	100	mA	CW
Output Power (SM, 9/125 μm)						
L	P _f	10	-	40	μW	I _{op} =80mA
M		30	-	60		
H		50	-	80		
U		100	-	-		
Output Power (MM, 50/125 μm)						
L	P _t	30	-	-	μW	I _{op} =80mA
M		50	-	-		
H		70	-	-		
Forward Voltage	V _f	-	1.2	2	V	CW
Rise Time	T _r	-	1.5	-	ns	-
Fall Time	T _f	-	2.5	-	ns	-
Output Power Variation		-	4	-	dB	25 to 70 , I _{op} =30mA

(All optical data refer to coupled 9/125 μm SM & 50/125 μm MM fiber)

Optical and Electrical Characteristics $\lambda=1550\text{nm}$ ($T_c=25^\circ\text{C}$)

Parameter	Symbol	Min.	Typ.	Max.	Unit	Notes
Peak Wavelength		1510	1550	1590	nm	CW
Spectral Width(RMS)		45	-	80	nm	CW
Operating Current	I_{op}	-	80	100	mA	CW
Output Power (SM, 9/125 μm)						
L	P_f	10	-	-	μW	$I_{op}=80\text{mA}$
M		20	-	-		
H		30	-	-		
Output Power (MM, 50/125 μm)						
L	P_t	20	-	-	μW	$I_{op}=80\text{mA}$
M		30	-	-		
H		40	-	-		
Forward Voltage	V_f	-	1.2	2	V	CW
Rise Time	T_r	-	1.5	-	ns	-
Fall Time	T_f	-	2.5	-	ns	-
Output Power Variation		-	4	-	dB	25 to 70 $^\circ\text{C}$, $I_{op}=30\text{mA}$

LD Pin Assignment

1: Option 1

Pin	Function
1	N/C
2	Anode
3	Cathode
4	N/C
5	N/C
6	Anode
7	Anode
8	N/C

2: Option 2

Pin	Function
1	Case GND
2	Anode
3	Cathode
4	Case GND
5	Case GND
6	Anode
7	Anode
8	Case GND

Packaging Dimension (Units in mm)

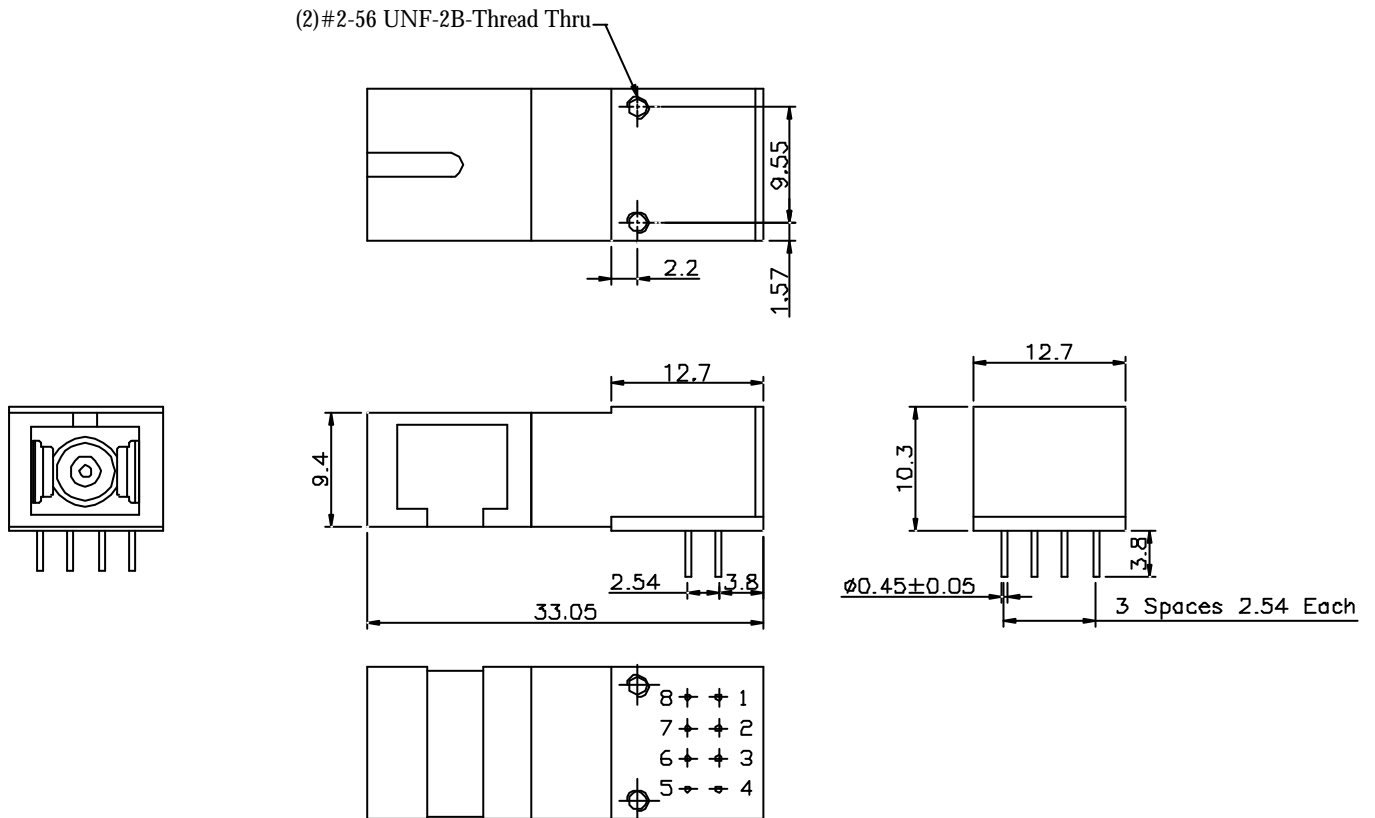

Ordering Information

SGC-GC-XXB-X-XXSC-XX

Family
SGC= Sugar Cube

Application
C=CW

Tolerance
B= +/- 40nm

Pinout
1=Option 1 (Tx)
2=Option 2 (Tx)

Connector
SC=SC

Device
G=ELED (Long)

Wavelength
30:1300nm
55:1550nm

Power
L/M/H

Fiber
S = Singlemode 9/125/900um
M = Multimode 50/125/900um

RoHS Compliant

Blank/G5/GR

Blank = RoHS non-compliant product

G5 = RoHS 5/6-compliant product (lead exemption)

GR = Full RoHS compliant product (no exemption)

Warnings

Handling Precautions: This device is susceptible to damage as a result of electrostatic discharge (ESD). A static free environment is highly recommended. Follow guidelines according to proper ESD procedures.

Laser Safety: Radiation emitted by laser devices can be dangerous to human eyes. Avoid eye exposure to direct or indirect radiation.

Legal Notice

IMPORTANT NOTICE!

All information contained in this document is subject to change without notice, at Source Photonics's sole and absolute discretion. Source Photonics warrants performance of its products to current specifications only in accordance with the company's standard one-year warranty; however, specifications designated as "preliminary" are given to describe components only, and Source Photonics expressly disclaims any and all warranties for said products, including express, implied, and statutory warranties, warranties of merchantability, fitness for a particular purpose, and non-infringement of proprietary rights. Please refer to the company's Terms and Conditions of Sale for further warranty information.

Source Photonics assumes no liability for applications assistance, customer product design, software performance, or infringement of patents, services, or intellectual property described herein. No license, either express or implied, is granted under any patent right, copyright, or intellectual property right, and Source Photonics makes no representations or warranties that the product(s) described herein are free from patent, copyright, or intellectual property rights. Products described in this document are NOT intended for use in implantation or other life support applications where malfunction may result in injury or death to persons. Source Photonics customers using or selling products for use in such applications do so at their own risk and agree to fully defend and indemnify Source Photonics for any damages resulting from such use or sale.

THE INFORMATION CONTAINED IN THIS DOCUMENT IS PROVIDED ON AN "AS IS" BASIS. Customer agrees that Source Photonics is not liable for any actual, consequential, exemplary, or other damages arising directly or indirectly from any use of the information contained in this document. Customer must contact Source Photonics to obtain the latest version of this publication to verify, before placing any order, that the information contained herein is current.

© Copyright Source Photonics, Inc. 2009

All rights reserved