

### Features

- XFP MSA Rev 4.5 compliant
- Available in all 100GHz C-Band Wavelengths on the DWDM ITU Grid
- Support multi-rate from 9.95G to 11.3G
- Up to 80km transmission on SMF
- Cooled EML with isolator and APD receiver
- XFI high speed electrical interface
- 2-wire interface with integrated Digital Diagnostic monitoring
- XFP MSA package with duplex LC connector
- +5.0V, +3.3V and +1.8V power supplies
- Power consumption less than 3.5 W
- Operating case temperature: -5~+70°C



### Regulatory Compliance

**Table 1 - Regulatory Compliance**

Feature	Standard	Performance
Electrostatic Discharge (ESD) to the Electrical Pins	MIL-STD-883E Method 3015.7	Class 1(>500V for XFI pins, >2000V for other pins.)
Electrostatic Discharge (ESD) to the Duplex LC Receptacle	IEC 61000-4-2 GR-1089-CORE	Compatible with standards
Electromagnetic Interference (EMI)	FCC Part 15 Class B EN55022 Class B (CISPR 22B) VCCI Class B	Compatible with standards
Immunity	IEC 61000-4-3	Compatible with standards
Laser Eye Safety	FDA 21CFR 1040.10 and 1040.11 EN60950, EN (IEC) 60825-1,2	Compatible with Class I laser product.
RoHS	2002/95/EC 4.1&4.2 2005/747/EC	Compliant with standards <sup>note</sup>

**Note:**

In light of item 5 in Annex of 2002/95/EC, "Pb in the glass of cathode ray tubes, electronic components and fluorescent tubes." and item 13 in Annex of 2005/747/EC, "Lead and cadmium in optical and filter glass.", the two exemptions are being concerned for Source Photonics transceivers, because Source Photonics transceivers use glass, which may contain Pb, for components such as lenses, windows, isolators, and other electronic components.

## Absolute Maximum Ratings

**Table 2 - Absolute Maximum Ratings**

Parameter	Symbol	Min.	Typical	Max.	Unit	Notes
Storage Temperature	$T_S$	-40	-	+85	°C	
Supply Voltage	$V_{CC5}$	-0.5	-	+6.0	V	
	$V_{CC3}$	-0.5	-	+4.0	V	
	$V_{CC2}$	-0.5	-	+2.0	V	
Operating Relative Humidity	RH	-	-	+85	%	
Damage Threshold for Receiver	$P_{IN-Damage}$	-	-	1	dBm	

## Recommended Operating Conditions

**Table 3 – Recommended Operating Conditions**

Parameter	Symbol	Min.	Typical	Max.	Unit	Notes
Operating Case Temperature	$T_C$	-5	-	+70	°C	
Power Supply Voltage	$V_{CC5}$	4.75	5.0	5.25	V	
	$V_{CC3}$	3.14	3.3	3.46	V	
	$V_{CC2}$	1.71	1.8	1.89	V	
Power Supply Current	$I_{CC5}$	-	-	500	mA	
	$I_{CC3}$	-	-	750	mA	
	$I_{CC2}$	-	-	1000	mA	
Power Dissipation	$P_D$	-	-	3.5	W	
Bit Rate	BR	9.95	-	11.3	Gbps	
Transmission Distance	TD	2	-	80,000	m	1

Note 1: Measured with G.652 SMF.

## Optical Characteristics

**Table 4 – Optical Characteristics**

Transmitter						
Parameter	Symbol	Min.	Typical	Max.	Unit	Notes
Center Wavelength Range	$\lambda_C$	1528.77	-	1563.86	nm	
	$f_C$	196.1	-	191.7	THz	
Channel Space	$\Delta f$	-	100	-	GHz	
Center Wavelength Tolerance	$\Delta \lambda_C$	-100	-	100	pm	
Average Output Power	$P_{OUT}$	0	2	4	dBm	1
Average Output Power (Laser Off)	$P_{OUT-OFF}$	-	-	-35	dBm	1

Side Mode Suppression Ratio	SMSR	35	-	-	dB	
Spectral Width (-20dB)	$\Delta\lambda_{20}$	-	-	0.3	nm	
Extinction Ratio	ER	9	-	-	dB	2
Dispersion Penalty at 1600 ps/nm	DP	-	-	2	dB	
Jitter Generation (peak-to-peak)	J <sub>P-P</sub>	-	-	0.1	UI	
Jitter Generation (RMS)	J <sub>RMS</sub>	-	-	0.01	UI	
Relative Intensity Noise	RIN	-	-	-130	dB/Hz	
Reflectance Tolerance	RT	-	-	-27	dB	
Optical Eye Mask	Compliant with ITU-T G.691-2006					2
<b>Receiver</b>						
Center Wavelength Range	$\lambda_C$	1528	-	1565	nm	
Receiver Sensitivity at 9.95Gbps	P <sub>IN-SENS@9.95G</sub>	-	-26	-24	dBm	3
Receiver Sensitivity at 11.1Gbps	P <sub>IN-SENS@11.1G</sub>	-	-24	-23	dBm	4
Receiver Overload	P <sub>IN-OL</sub>	-7	-	-	dBm	3
Optical Return Loss	ORL	-	-	-27	dB	
LOS Assert	LOS <sub>A</sub>	-34	-	-	dBm	
LOS Deassert	LOS <sub>D</sub>	-	-	-24	dBm	
LOS Hysteresis	LOS <sub>H</sub>	0.5	-	4	dB	

## Notes:

1. The optical power is launched into SMF.
2. Measured with a PRBS 2<sup>31</sup>-1 test pattern @9.95Gbps.
3. Measured with a PRBS 2<sup>31</sup>-1 test pattern @9.95Gbps, BER≤10<sup>-12</sup>.
4. Measured with a PRBS 2<sup>31</sup>-1 test pattern @11.1Gbps, BER≤10<sup>-12</sup>.

## Electrical Characteristics

Table 5 – Electrical Characteristics

<b>Transmitter</b>						
Parameter	Symbol	Min.	Typical	Max.	Unit	Notes
Differential Data Input Amplitude	V <sub>IN,P-P</sub>	120	-	820	mVpp	
Input Differential Impedance	Z <sub>IN</sub>	80	100	120	Ω	
Tx_Disable, P_Down/RST	V <sub>IL</sub>	-0.3	-	0.8	V	
	V <sub>IH</sub>	2.0	-	V <sub>CC</sub> +0.3	V	
<b>Receiver</b>						
Differential Data Output Amplitude	V <sub>OUT,P-P</sub>	340	-	850	mVpp	
Output Differential Impedance	Z <sub>d</sub>	80	100	120	Ω	
Output Rise Time, 20%~80%	T <sub>R</sub>	24	-	-	ps	
Output Fall Time, 20%~80%	T <sub>F</sub>	24	-	-	ps	
Rx_LOS, Mod_NR, Interrupt	V <sub>OL</sub>	0	-	0.4	V	
	V <sub>OH</sub>	V <sub>CC</sub> -0.5	-	V <sub>CC</sub> +0.3	V	

## Recommended Host Board Power Supply Circuit

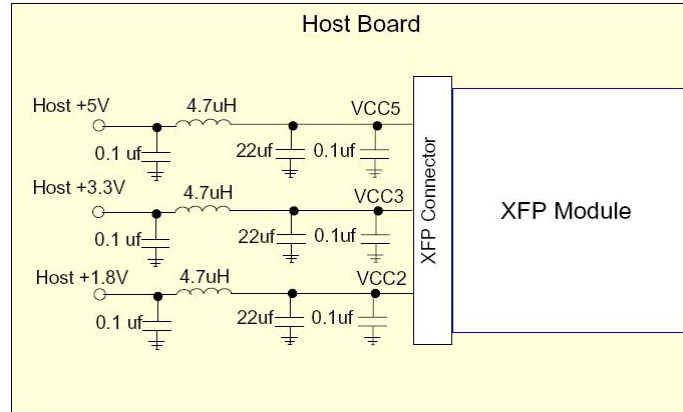

Figure 1, Recommended Host Board Power Supply Circuit

## Recommended Interface Circuit

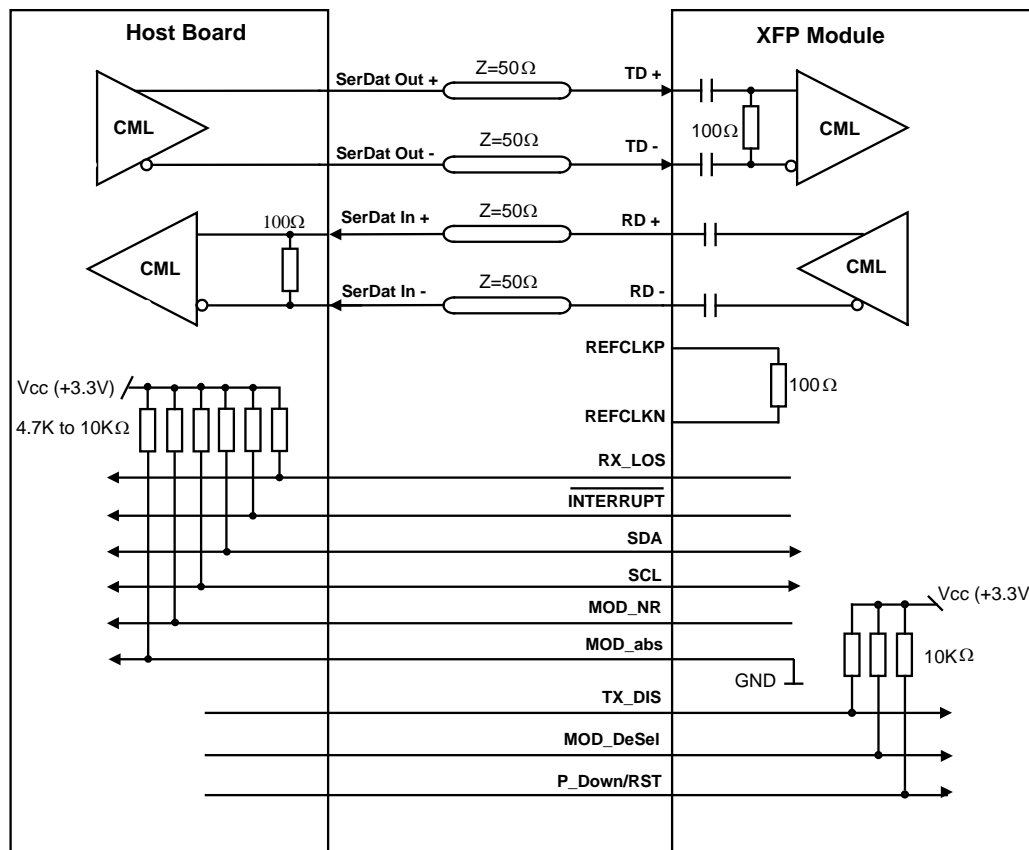

Figure 2, Recommended Interface Circuit

## Pin Definitions

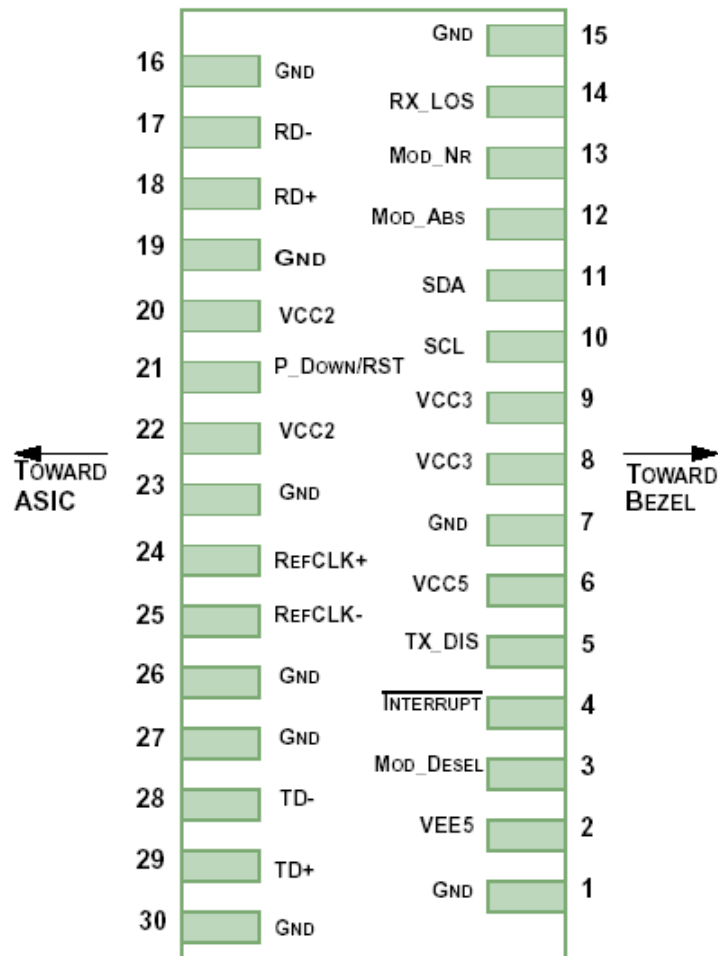

Figure 3, Pin View

Table 6 – Electrical Characteristics

Pin	Logic	Symbol	Name/Description	Note
1		GND	Module Ground	1
2		V <sub>EE5</sub>	Optional -5.2V Power Supply (Not implemented)	3
3	LVTTL-I	Mod_Desel	Module De-select; When held low allows the module to respond to 2-wire serial interface	
4	LVTTL-O	Interrupt	Interrupt; Indicates presence of an important condition which can be read over the 2-wire serial interface	2
5	LVTTL-I	TX_DIS	Transmitter Disable; Turns off transmitter laser output	
6		V <sub>CC5</sub>	+5V Power Supply	
7		GND	Module Ground	1
8		V <sub>CC3</sub>	+3.3V Power Supply	
9		V <sub>CC3</sub>	+3.3V Power Supply	
10	LVTTL-I/O	SCL	2-Wire Serial Interface Clock	2
11	LVTTL-I/O	SDA	2-Wire Serial Interface Data Line	2

12	LVTTL-O	Mod_Abs	Indicates Module is not present. Grounded in the Module	2
13	LVTTL-O	Mod_NR	Module Not Ready; Indicating Module Operational Fault	2
14	LVTTL-O	RX_LOS	Receiver Loss Of Signal Indicator	2
15		GND	Module Ground	1
16		GND	Module Ground	1
17	CML-O	RD-	Receiver Inverted Data Output	
18	CML-O	RD+	Receiver Non-Inverted Data Output	
19		GND	Module Ground	1
20		V <sub>CC2</sub>	+1.8V Power Supply	
21	LVTTL-I	P_Down/RST	Power down; When high, requires the module to limit power consumption to 1.5W or below. 2-Wire serial interface must be functional in the low power mode.	
			Reset; The falling edge initiates a complete reset of the module including the 2-wire serial interface, equivalent to a power cycle.	
22		V <sub>CC2</sub>	+1.8V Power Supply	
23		GND	Module Ground	1
24	PECL-I	RefCLK+	Not used, internally terminated to 50ohm (100ohm diff).	4
25	PECL-I	RefCLK-	Not used, internally terminated to 50ohm (100ohm diff).	4
26		GND	Module Ground	1
27		GND	Module Ground	1
28	CML-I	TD-	Transmitter Inverted Data Input	
29	CML-I	TD+	Transmitter Non-Inverted Data Input	
30		GND	Module Ground	1

## Notes:

1. Module ground pins GND are isolated from the module case and chassis ground within the module.
2. Shall be pulled up with 4.7K-10Kohms to a voltage between 3.15V and 3.45V on the host board.
3. The pins are open within module.
4. Reference Clock is not required

## Mechanical Diagram

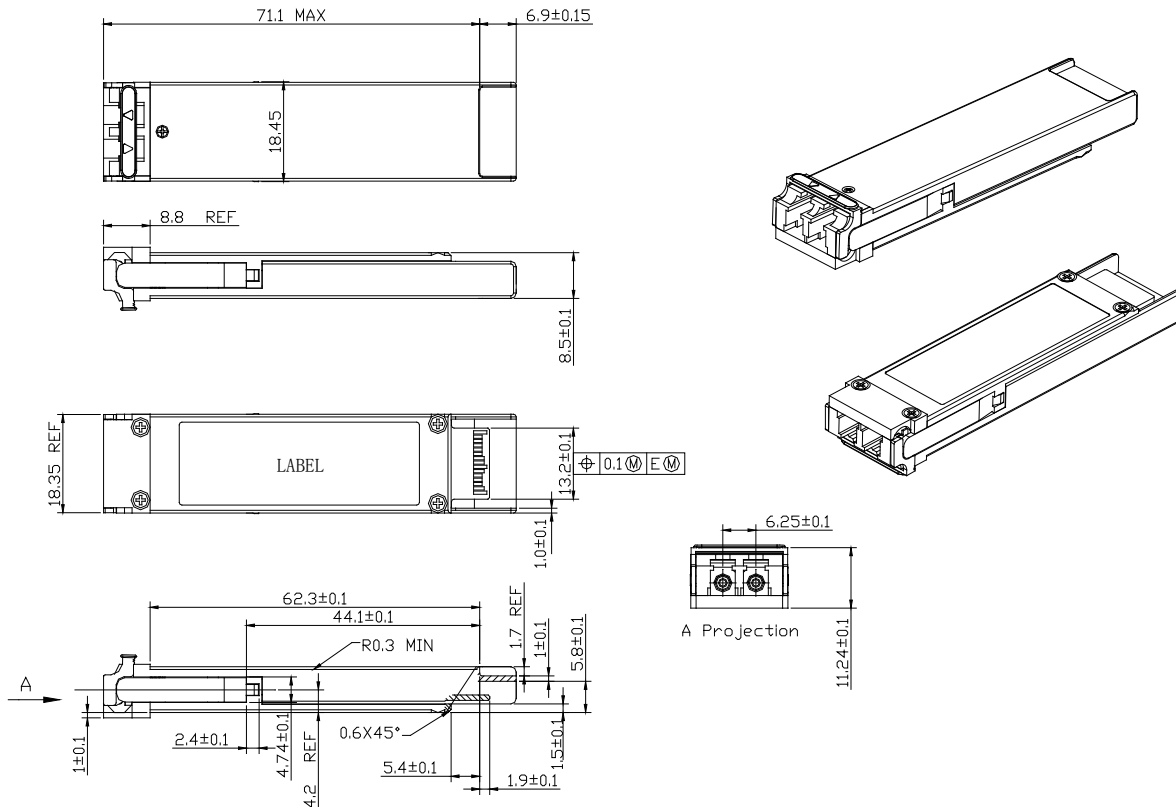

Figure 4, Mechanical Diagram of XFP

## Order Information

Table 7 – Order Information

Part No.	Application	Data Rate	Laser Source	Fiber Type
XPD-MR-08-xxCDFA	L-64.2a 10GBASE-ZR	9.95G~11.3G	DWDM EML	SMF

Note: see Table 10 – Wavelength Guide for “xx” value

Table 10 – Wavelength Guide (xx value)

ITU Channel (xx)	Frequency (THz)	Wavelength (nm)	ITU Channel (xx)	Frequency (THz)	Wavelength (nm)
17*	191.7	1563.863	40	194.0	1545.322
18	191.8	1563.047	41	194.1	1544.526
19	191.9	1562.233	42	194.2	1543.730
20	192.0	1561.419	43	194.3	1542.936
21	192.1	1560.606	44	194.4	1542.142
22	192.2	1559.794	45	194.5	1541.349
23	192.3	1558.983	46	194.6	1540.557

24	192.4	1558.173	47	194.7	1539.766
25	192.5	1557.363	48	194.8	1538.976
26	192.6	1556.555	49	194.9	1538.186
27	192.7	1555.747	50	195.0	1537.397
28	192.8	1554.940	51	195.1	1536.609
29	192.9	1554.134	52	195.2	1535.822
30	193.0	1553.329	53	195.3	1535.036
31	193.1	1552.524	54	195.4	1534.250
32	193.2	1551.721	55	195.5	1533.465
33	193.3	1550.918	56	195.6	1532.681
34	193.4	1550.116	57	195.7	1531.898
35	193.5	1549.315	58	195.8	1531.116
36	193.6	1548.515	59	195.9	1530.334
37	193.7	1547.715	60	196.0	1529.553
38	193.8	1546.917	61	196.1	1528.773
39	193.9	1546.119			

Note: \*This channel is supported with special request -- Please contact Source Photonics for further details.

## Warnings

**Handling Precautions:** This device is susceptible to damage as a result of electrostatic discharge (ESD). A static free environment is highly recommended. Follow guidelines according to proper ESD procedures.

**Laser Safety:** Radiation emitted by laser devices can be dangerous to human eyes. Avoid eye exposure to direct or indirect radiation.

## Legal Notice

### IMPORTANT NOTICE!

All information contained in this document is subject to change without notice, at Source Photonics's sole and absolute discretion. Source Photonics warrants performance of its products to current specifications only in accordance with the company's standard one-year warranty; however, specifications designated as "preliminary" are given to describe components only, and Source Photonics expressly disclaims any and all warranties for said products, including express, implied, and statutory warranties, warranties of merchantability, fitness for a particular purpose, and non-infringement of proprietary rights. Please refer to the company's Terms and Conditions of Sale for further warranty information.

Source Photonics assumes no liability for applications assistance, customer product design, software performance, or infringement of patents, services, or intellectual property described herein. No license, either express or implied, is granted under any patent right, copyright, or intellectual property right, and Source Photonics makes no representations or warranties that the product(s) described herein are free from patent, copyright, or intellectual property rights. Products described in this document are NOT intended for use in implantation or other life support applications where malfunction may result in injury or death to persons. Source Photonics customers using or selling products for use in such applications do so

at their own risk and agree to fully defend and indemnify Source Photonics for any damages resulting from such use or sale.

THE INFORMATION CONTAINED IN THIS DOCUMENT IS PROVIDED ON AN "AS IS" BASIS. Customer agrees that Source Photonics is not liable for any actual, consequential, exemplary, or other damages arising directly or indirectly from any use of the information contained in this document. Customer must contact Source Photonics to obtain the latest version of this publication to verify, before placing any order, that the information contained herein is current.

## Contact

### U.S.A. Headquarters

20550 Nordhoff Street  
Chatsworth, CA 91311  
USA  
Tel: +1-818-773-9044  
Fax: +1-818-773-0261

### China

Building #2&5, West Export Processing Zone  
No. 8 Kexin Road, Hi-Tech Zone  
Chengdu, 611731, China  
Tel: +86-28-8795-8788  
Fax: +86-28-8795-8789

### Taiwan

9F, No 81, Shui Lee Rd.  
Hsinchu, Taiwan, R.O.C.  
Tel: +886-3-5169222  
Fax: +886-3-5169213

© Copyright Source Photonics, Inc. 2008~2009

All rights reserved