



Features

- Duplex LC Single Mode Transceiver
- Small Form Factor Multi-sourced 2x5 Pin Package
- Ultra Long reach SONET OC-3/SDH STM-1 Compliant
- Single +3.3V Power Supply
- LVPECL Differential Inputs and Outputs
- LVPECL Signal Detection Output
- Temperature Range: 0 to 70 °C
- Class 1 Laser International Safety Standard IEC 825 Compliant
- Solder ability to MIL-STD-883, Method 2003
- Flammability to UL94V0
- Humidity RH 5-85% (5-95% short term) to IEC 68-2-3
- Complies with Telcordia(Bellcore) GR-468-CORE
- Uncooled Laser Diode with MQW Structure
- EMI Shielding Finger Optional
- ATM 155 Mbps links
- RoHS Compliance Available

Table 1 – Absolute Maximum Rating

Parameter	Symbol	Min.	Typical	Max.	Unit	Notes
Power Supply Voltage	V _{cc}	0	-	3.6	V	
Output Current	I _{out}	-	-	30	mA	
Soldering Temperature	-	-	-	260	°C	1
Storage Temperature	T _{stg}	-40	-	85	°C	

Note 1: 10 seconds on leads only

Table 2 – Recommended Operating Condition

Parameter	Symbol	Min.	Typical	Max.	Unit	Notes
Power Supply Voltage	V _{cc}	3.1	3.3	3.5	V	
Operating Temperature (Case)	T _{opr}	0	-	70	°C	
Data Rate	DR	-	155	-	Mbps	

Table 3 – Transmitter Specifications (Optical)

Parameter	Symbol	Min.	Typical	Max.	Unit	Notes
Optical Transmit Power	P_o	-15	-	-3	dBm	
Output Center Wavelength	λ_c	1261	1310	1360	nm	
Output Spectrum Width	$\Delta \lambda$	-	-	7.7	nm	
Optical Rise/Fall Time	t_r / t_f	-	-	2	ns	2
Extinction Ratio	ER	8.2	-	-	dB	
Output Eye		Compliant with Bellcore GR-253-CORE and ITU Recommendation				
Relative Intensity Noise	RIN	-	-	-116	dB/Hz	
Total Jitter	T_J	-	-	1.2	ns	3

Note 2: 10% to 90% Values

Note 3: Measured with $2^{23}-1$ PRBS with 72 ones and 72 zeros.

Table 4 – Transmitter Specifications (Electrical)

Parameter	Symbol	Min.	Typical	Max.	Unit	Notes
Power Supply Current	I_{CC}	-	-	180	mA	4
Transmitter Enable Voltage	V_{EN}	0	-	0.8	V	
Transmitter Disable Voltage	V_D	2	-	V_{CC}	V	
Data Input Current-Low	I_{IL}	-200	-	-	μA	
Data Input Current-High	I_{IH}	-	-	200	μA	
Data Input Voltage-Low	$V_{IL}-V_{CC}$	-2.0	-	-1.58	V	5
Data Input Voltage-High	$V_{IH}-V_{CC}$	-1.1	-	-0.74	V	5

Note 4: Maximum current is specified at $V_{CC} = \text{Maximum}$ @ maximum temperature

Note 5: These inputs are compatible with 10K, 10KH and 100K ECL and PECL inputs

Table 5 – Receiver Specifications (Optical)

Parameter	Symbol	Min.	Typical	Max.	Unit	Notes
Sensitivity	-	-	-	-34	dBm	6
Maximum Input Power	P_{in}	-3	-	-	dBm	
Signal Detect-Asserted	P_a	-	-	-32	dBm	
Signal Detect-Deasserted	P_d	-48	-	-	dBm	
Signal Detect-Hysteresis	-	1	-	4	dB	
Wavelength of Operation	-	1100	-	1600	nm	

Note 6: Measured with $2^{23}-1$ PRBS/BER = 10^{-10}

Table 6 – Receiver Specifications (Electrical)

Parameter	Symbol	Min.	Typical	Max.	Unit	Notes
Power Supply Current	I_{CC}	-	-	100	mA	7
Data Output Voltage-Low	$V_{OL}-V_{CC}$	-2	-	-1.58	V	8
Data Output Voltage-High	$V_{OH}-V_{CC}$	-1.1	-	-0.74	V	8
Signal Detect Output Voltage-Low	$V_{SDL}-V_{CC}$	-2	-	-1.58	V	
Signal Detect Output Voltage-High	$V_{SDH}-V_{CC}$	-1.1	-	-0.74	V	

Note 7: The current excludes the output load current

Note 8: These outputs are compatible with 10K, 10KH and 100KECL and LVPECL outputs.

Connection Diagram

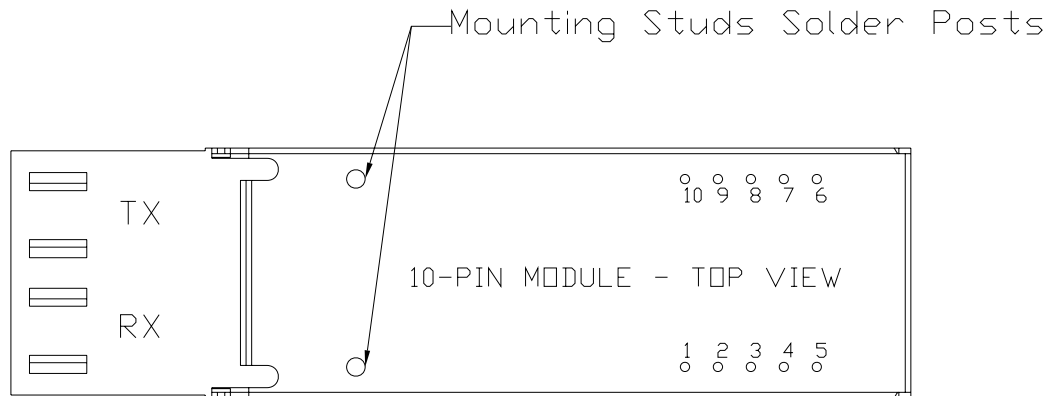
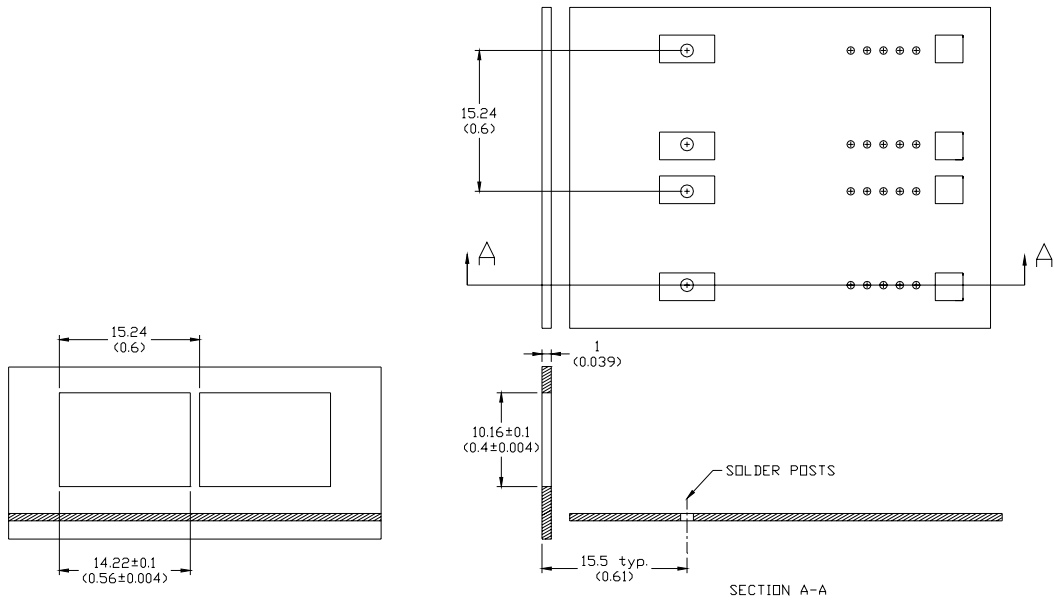

Table 7 – Pin Definitions

Pin	Unit	Notes
1	RxGND	Directly connect this pin to the receiver ground plane
2	RxVcc	+3.3V dc power for the receiver section
3	SD	Active high on this indicates a received optical signal (LVPECL)
4	RD-	Receiver Data Out Bar (LVPECL)
5	RD+	Receiver Data Out (LVPECL)
6	TxVcc	+3.3V DC power for the transmitter section
7	TxGND	Directly connect this pin to the Transmitter ground plane
8	TxDIS	Transmitter Disable (LVTTTL)
9	TD+	Transmitter Data In (LVPECL)
10	TD-	Transmitter Data In Bar (LVPECL)
Attaching Posts		The attaching posts are at case potential and may be connected to chassis ground. They are isolated from circuit ground.

Recommended Panel Mounting



DIMENSION IN MILLIMETER (INCHES)

Order Information

Table 8 – Order Information

Part No.
C-13-155-F-SLC3S-19
C-13-155-F-SLC3S-19-G5

Part Numbering Definition:

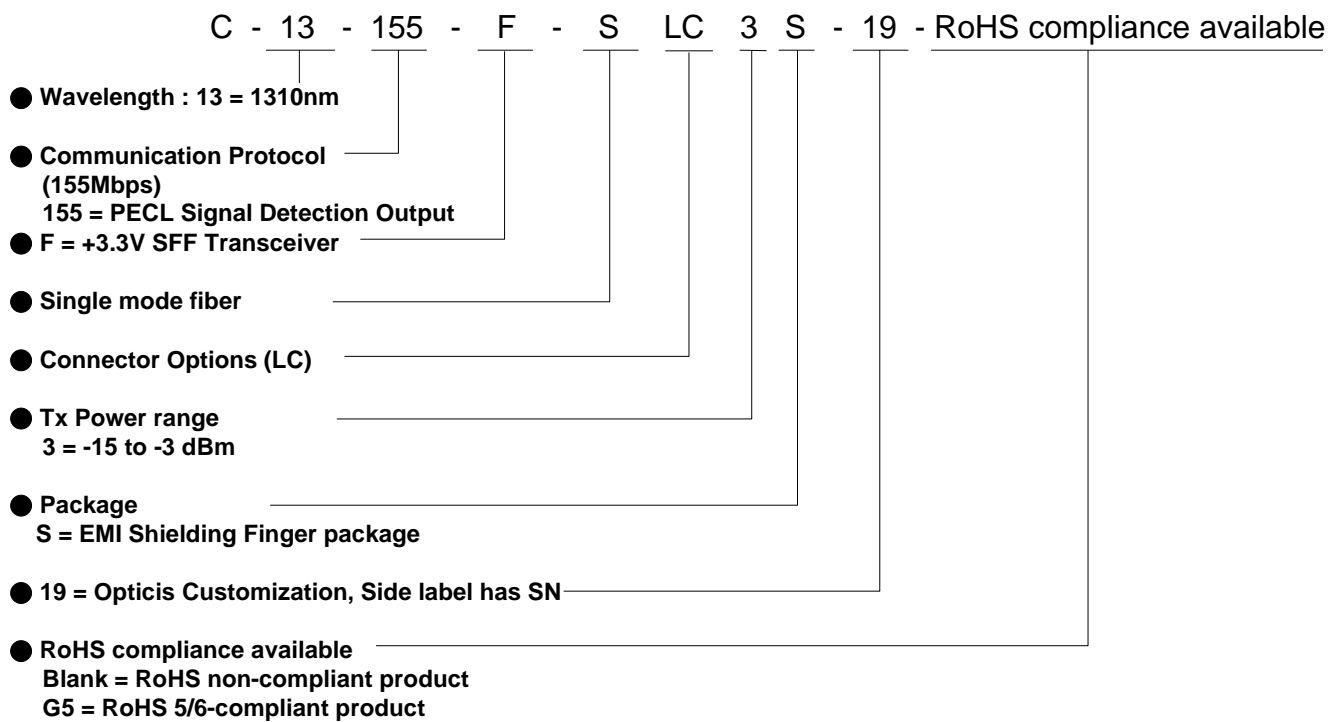

Warnings

Handling Precautions: This device is susceptible to damage as a result of electrostatic discharge (ESD). A static free environment is highly recommended. Follow guidelines according to proper ESD procedures.

Laser Safety: Radiation emitted by laser devices can be dangerous to human eyes. Avoid eye exposure to direct or indirect radiation.

Legal Notice

IMPORTANT NOTICE!

All information contained in this document is subject to change without notice, at Source Photonics' sole and absolute discretion. Source Photonics warrants performance of its products to current specifications only in accordance with the company's standard one-year warranty; however, specifications designated as "preliminary" are given to describe components only, and Source Photonics expressly disclaims any and all warranties for said products, including express, implied, and statutory warranties, warranties of merchantability, fitness for a particular purpose, and non-infringement of proprietary rights. Please refer to the company's Terms and Conditions of Sale for further warranty information.

Source Photonics assumes no liability for applications assistance, customer product design, software performance, or infringement of patents, services, or intellectual property described herein. No license, either express or implied, is granted under any patent right, copyright, or intellectual property right, and Source Photonics makes no representations or warranties that the product(s) described herein are free from patent, copyright, or intellectual property rights. Products described in this document are NOT intended for use in implantation or other life support applications where malfunction may result in injury or death to persons. Source Photonics customers using or selling products for use in such applications do so at their own risk and agree to fully defend and indemnify Source Photonics for any damages resulting from such use or sale.

THE INFORMATION CONTAINED IN THIS DOCUMENT IS PROVIDED ON AN "AS IS" BASIS. Customer agrees that Source Photonics is not liable for any actual, consequential, exemplary, or other damages arising directly or indirectly from any use of the information contained in this document. Customer must contact Source Photonics to obtain the latest version of this publication to verify, before placing any order, that the information contained herein is current.

Contact

U.S.A. Headquarters

20550 Nordhoff Street
Chatsworth, CA 91311
USA

Tel: +1-818-773-9044

Fax: +1-818-773-0261

sales@sourcephotonics.com

China

Building #2&5, West Export Processing Zone
No. 8 Kexin Road, Hi-Tech Zone
Chengdu, 611731, China

Tel: +86-28-8795-8788

Fax: +86-28-8795-8789

sales@sourcephotonics.com.cn

Taiwan

9F, No 81, Shui Lee Rd.
Hsinchu, 300, Taiwan
R.O.C.

Tel: +886-3-5169222

Fax: +886-3-5169213

sales@sourcephotonics.com.tw

© Copyright Source Photonics, Inc. 2007~2008

All rights reserved